

BAG HOUSE DUST COLLECTION SYSTEM

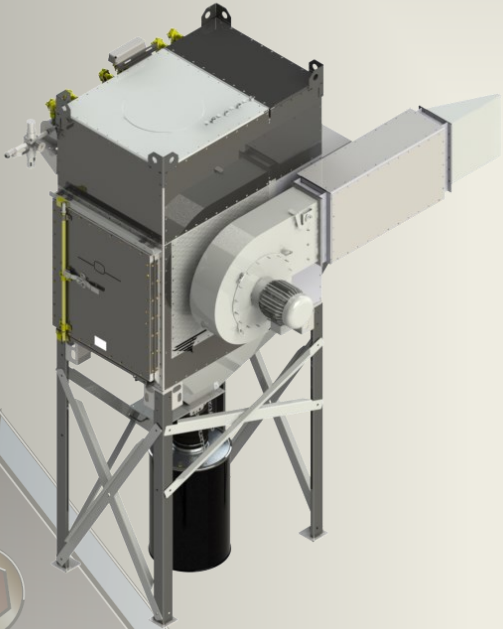

Saving energy and increasing production efficiency while controlling indoor air quality is a challenging aspect of plant management. Dust collectors—whether used for pollution control or product recovery can impact all these areas.

Side Mount Blower



- Meets 5 mg/m³ or less emissions requirements to recirculate air back on non-hazardous dusts, in most cases.
- Each module accommodates airflows up to 5,000 cfm
- Module constructed of 7 gauge carbon steel
- Door, hopper, inlet and panels are all 10 gauge steel
- Powder coated for unsurpassed corrosion resistance
- Vertical design of cartridges enables efficient pulse cleaning of dust

Top Mount Blower

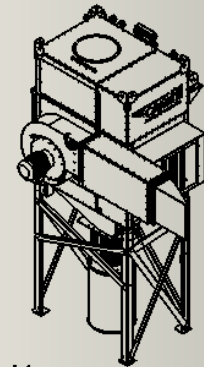
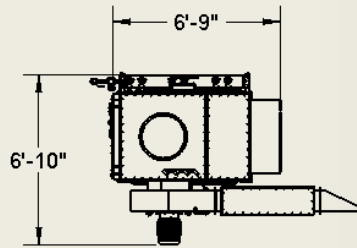
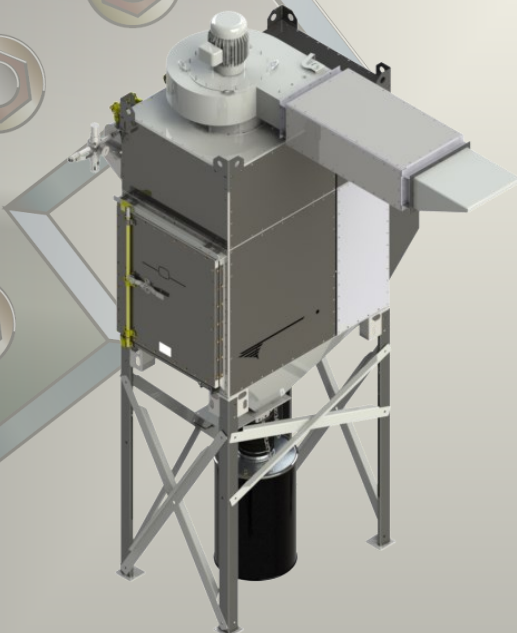

**Approx. Weight:
2,300 lbs**

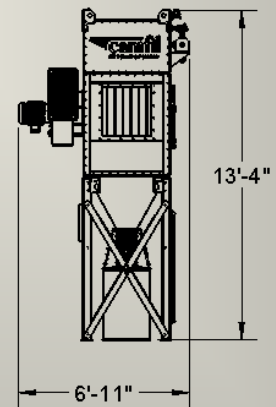
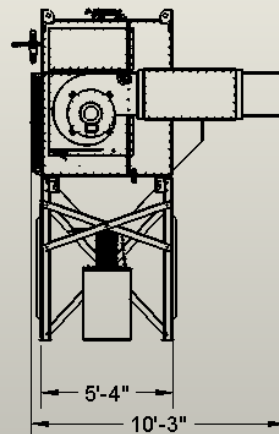

Hub City Iron Works

Phone: 1.337.334.6969

Email: sales@hubcityironworks.com

Website: www.hubcityironworks.com