

HYDROSTATIC TESTING MACHINE

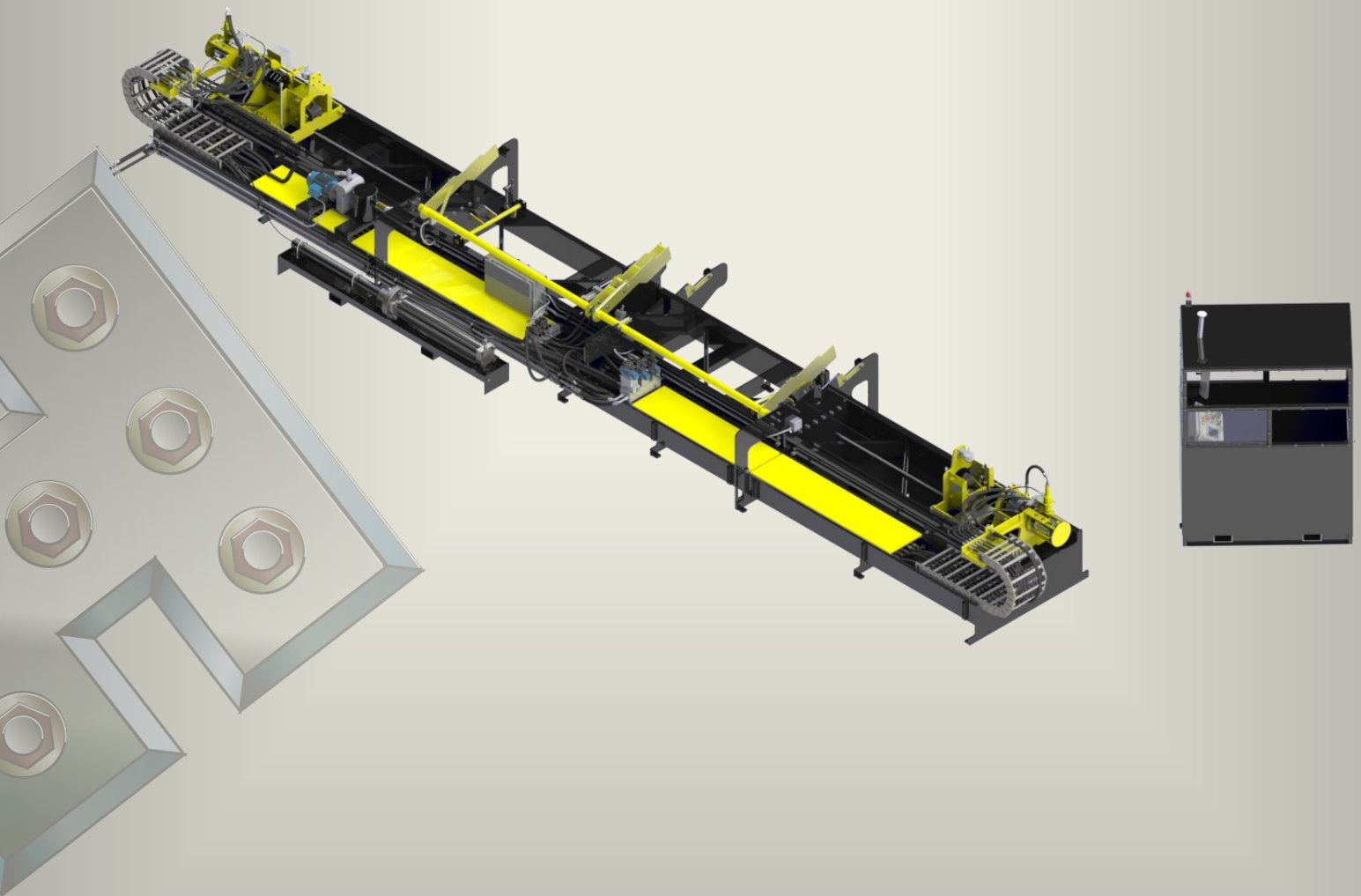

The Hub City Iron Works Hydrostatic Testing Machine is a safety oriented product used to pressure test tubulars up to 20,000 PSI in order to meet regulatory specifications. The unit utilizes test mandrels with motorized rotation allowing for appropriate torque application, ultimately enabling high quality and consistent test operations.



Hub City Iron Works
Phone: 1.337.334.6969

Email: sales@hubcityironworks.com
Website: www.hubcityironworks.com

Standard Features

- Operator controlled loading and unloading of pipe
- Easy to use touch screen interface
- Hydraulic power supply
- Heavy duty clamp assembly
- Range 2 pipe capability
- Safety cage for operator

Capability

- 2-3/8" thru 4-1/2" (Casing and Tubing)

Optional Features

- Range 3 pipe capability
- Proprietary mandrels
- Camera system
- Data recording

Safety Features

- Mechanically active components painted safety yellow
- Low voltage operator interface
- Equipment safety labels
- Operator safety cage with door activated switch

Requirements

- Electrical: 220/480V, 3-Phase, 60 Hz
- Compressed Air: N/A
- Rack Height: 42"

DIMENSIONS

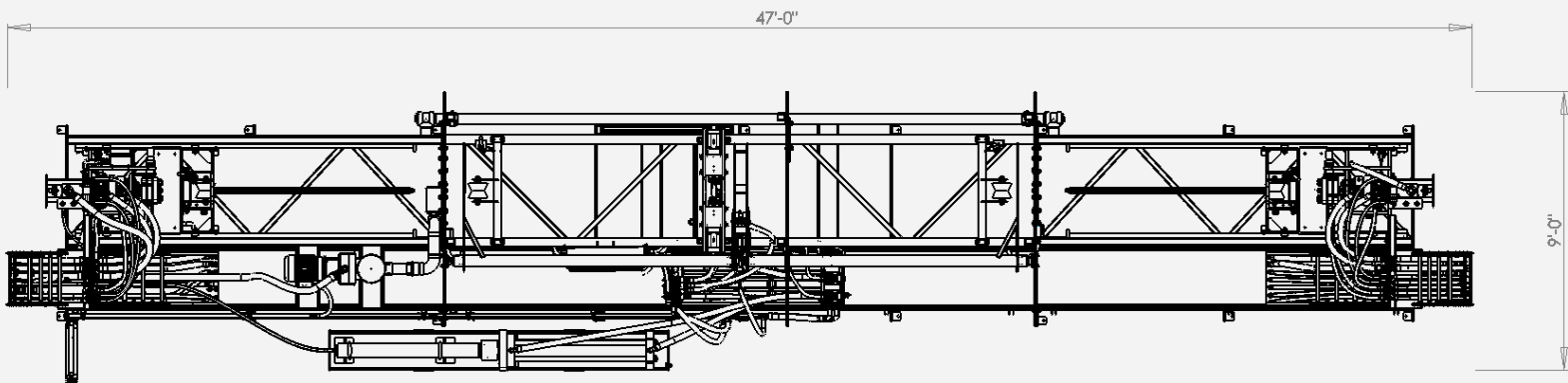

Hub City Iron Works

Phone: 1.337.334.6969

Email: sales@hubcityironworks.com

Website: www.hubcityironworks.com

