

LOADING CONVEYOR

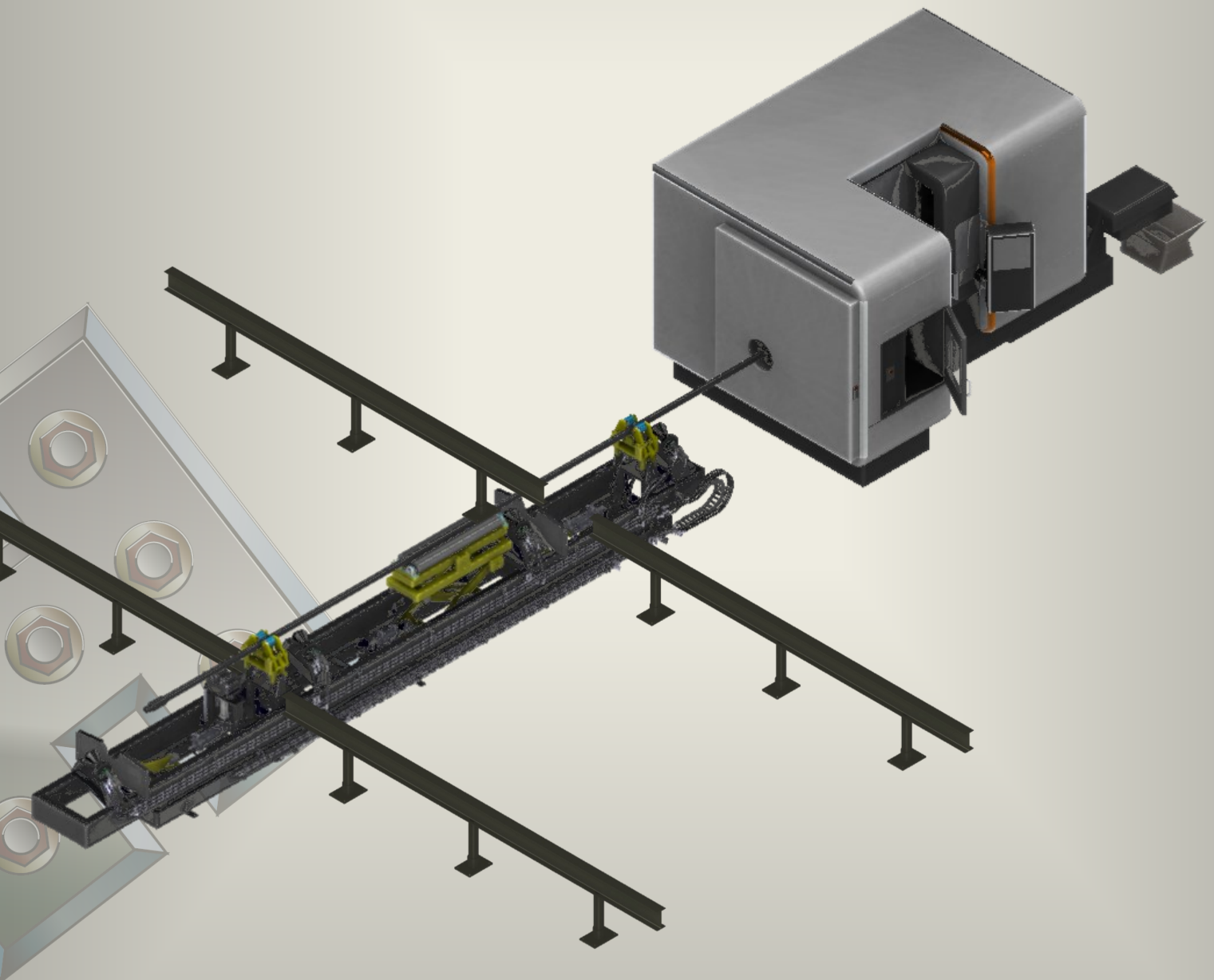

The Hub City Iron Works Loading Conveyor is designed to facilitate the safe and efficient loading of tubular goods for lathe operations. With features like height repeatability and safety roller clamps, its user friendly controls and functionality streamline the loading process and provide operators an intuitive solution for pipe handling during machining operations.



Hub City Iron Works
Phone: 1.337.334.6969

Email: sales@hubcityironworks.com
Website: www.hubcityironworks.com

Standard Features

- 4 ft. support rollers
- Onboard PLC
- Easy to use operator interface
- Hydraulic power supply
- Hydraulically powered V-Rollers

Capability

| | |
|------------------------|-----------|
| Pipe Minimum OD | 1" |
| Pipe Maximum OD | 10-3/4" |
| Maximum Weight | 7,500 lbs |

Optional Features

- Clamp roller assemblies for higher cutting speeds
- Support rollers to handle various lengths of pipe up to Range3

Safety Features

- Mechanically active components are painted safety yellow
- Clamps
- Low voltage operator interface

Requirements

- Electrical: 220/480V, 3-Phase, 60 Hz
- Compressed Air: N/A
- Rack Height: 36"-46" (Max difference between lathe center-line and rack top is 7")
- Flat and level concrete surface

DIMENSIONS

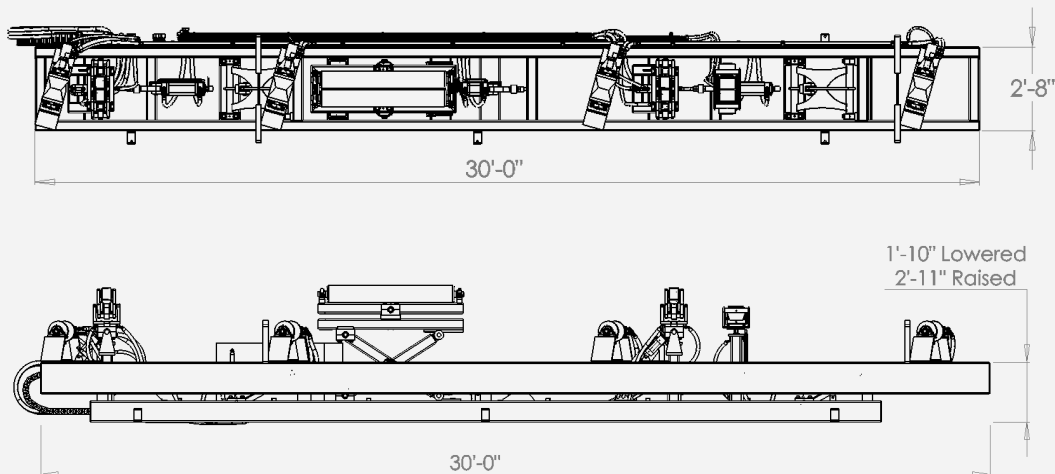

Hub City Iron Works

Phone: 1.337.334.6969

Email: sales@hubcityironworks.com

Website: www.hubcityironworks.com

