

PIPE STRAIGHTENING MACHINE-TM

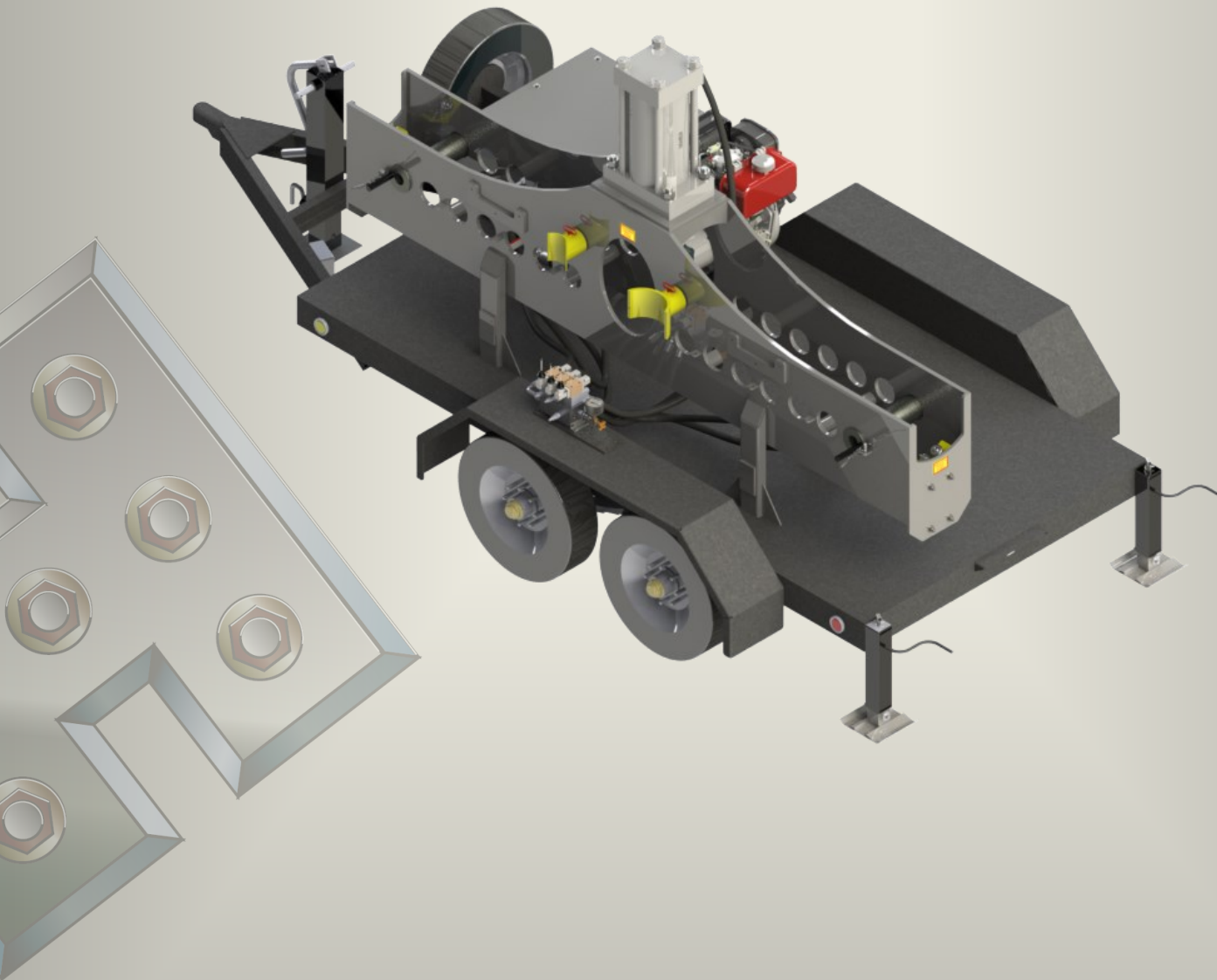

The Hub City Iron Works PSM-TM is a ram-type Pipe Straightening Machine that is conveniently mounted on a trailer, making it easily relocated.. With 75-Ton capacity, the PSM-TM can straighten any standard oilfield tubular.



Hub City Iron Works

Phone: 1.337.334.6969

Email: sales@hubcityironworks.com

Website: www.hubcityironworks.com

Standard Features

- Skid-Mounted ram-type pipe straightener with forklift pockets
- Adjustable pins for variable pipe bending locations
- Height adjustable modular pipe conveyor system
- Hydraulic pop-up rollers on each frame end for manual rotation of pipe
- Straightening shoes to fit pipe from 2-3/8" to 6-5/8"
- 3,000 PSI hydraulic system with manual control valves

Capability

- Pipe straightening ability depends on location of the bend
- Specific sizes and weights can be calculated by request
- Grade S-135 pipe calculated below
- Dimension "A" is the minimum distance from the upset to the bent area

Model	Max Drill Pipe Size	Max Drill Pipe Size	Max Drill Collar Size
Dim "A"	18"	48"	48"
PSM-TM	5-1/2" 24.7 #/ft.	6-5/8" 27.7 #/ft.	6" OD x 1-1/2" ID

Optional Features

- Diesel/Gas engine with electric start
- Trailer-mounted (Ball hitch / 5th wheel)
- Hydraulic pipe conveyor system
- Hydraulic pop-up system
- Pad eyes for crane lifting
- Custom sized straightening shoes

Safety Features

- Moving items painted high visibility safety yellow
- Pipe is straightened within frame
- Pipe guard envelops work piece

Requirements

- Electrical: N/A
- Compressed Air: N/A
- Rack Height: 36"-44"

DIMENSIONS

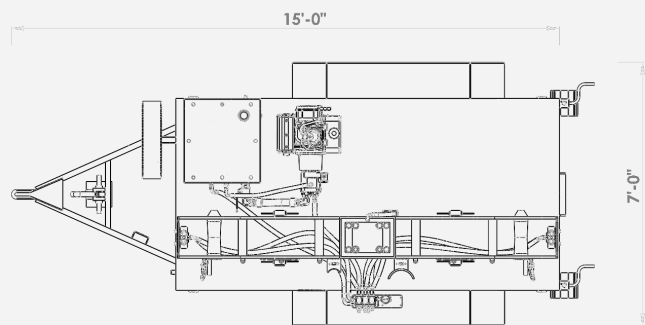
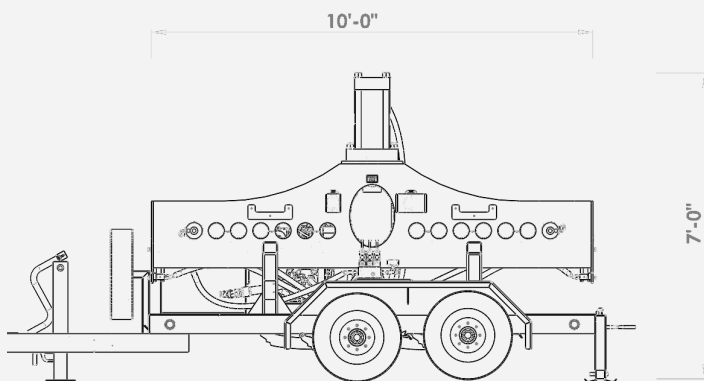

Hub City Iron Works

Phone: 1.337.334.6969

Email: sales@hubcityironworks.com

Website: www.hubcityironworks.com

