

PIPE STRAIGHTENING MACHINE

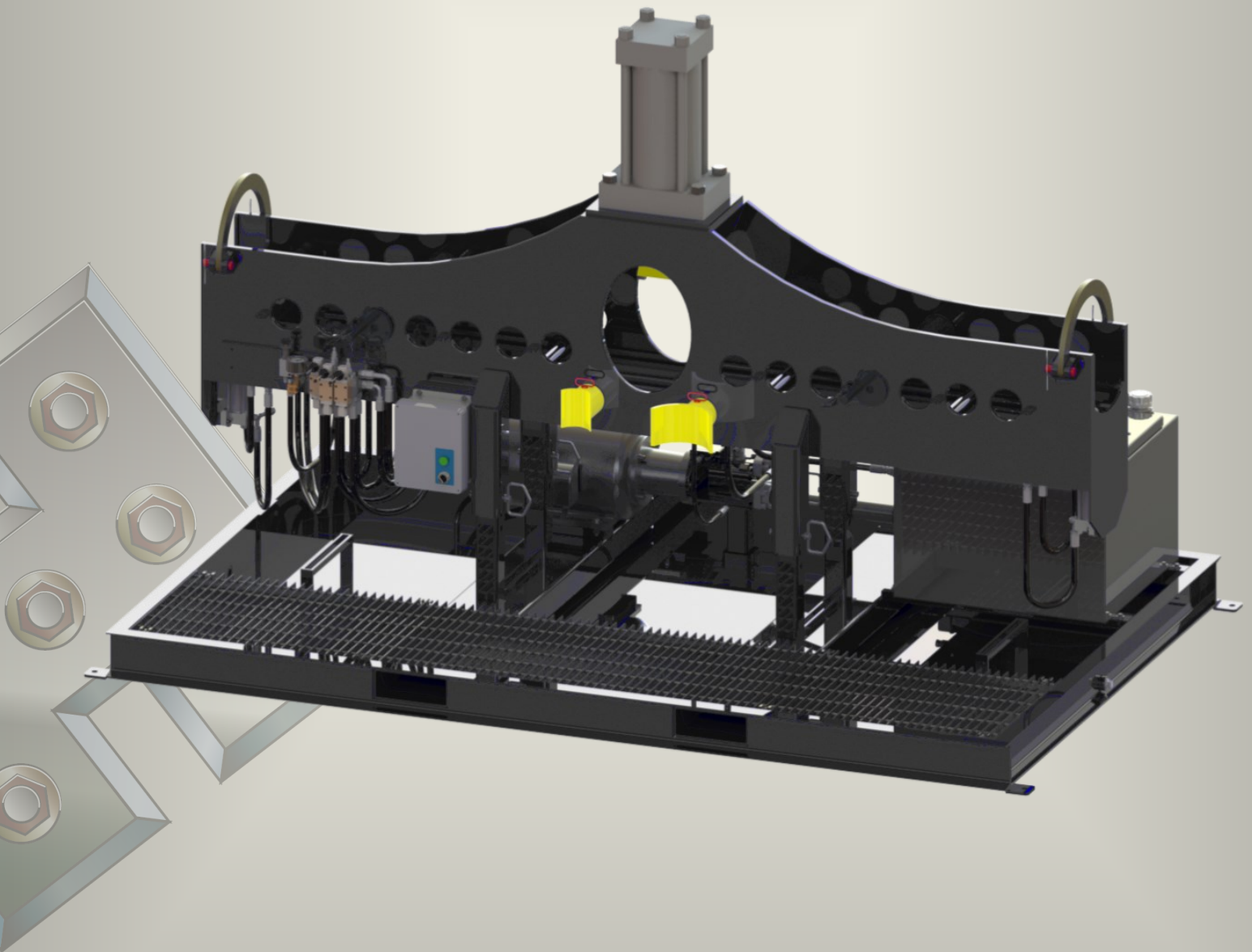

The Hub City Iron Works PSM is a ram-type Pipe Straightening Machine that is available as a self-contained skid-mounted unit, a stationary unit for permanent plant installations or a portable trailer-mounted unit. With capacity options ranging from 75-Ton to 250-Ton, the PSM can straighten any standard oilfield tubular.



Hub City Iron Works
Phone: 1.337.334.6969

Email: sales@hubcityironworks.com
Website: www.hubcityironworks.com

Standard Features

- Skid-Mounted ram-type pipe straightener with forklift pockets
- Adjustable pins for variable pipe bending locations
- Height adjustable modular pipe conveyor system
- Hydraulic pop-up rollers on each frame end for manual rotation of pipe
- Straightening shoes to fit pipe from 2-3/8" to 6-5/8"
- 3,000 PSI hydraulic system with manual control valves

Capability

- Pipe straightening ability depends on location of the bend
- Specific sizes and weights can be calculated by request
- Grade S-135 pipe calculated below
- Dimension "A" is the minimum distance from the upset to the bent area

Model	Max Drill Pipe Size	Max Drill Pipe Size	Max Drill Collar Size
Dim "A"	18"	48"	48"
75 Ton	5-1/2" 24.7 #/ft.	6-5/8" 27.7 #/ft.	6" OD x 1-1/2" ID
125 Ton	6-5/8" 27.7 #/ft.	6-5/8" 27.7 #/ft.	7" OD x 1-1/2" ID
250 Ton	6-5/8" 27.7 #/ft.	6-5/8" 27.7 #/ft.	9" OD x 1-1/2" ID

Optional Features

- Diesel/Gas engine with electric start
- Trailer-mounted (Ball hitch / 5th wheel)
- Hydraulic pipe conveyor system
- Hydraulic pop-up system
- Pad eyes for crane lifting
- Custom sized straightening shoes

Safety Features

- Moving items painted high visibility safety yellow
- Pipe is straightened within frame
- Pipe guard envelops work piece

Requirements

- Electrical: 220/480V, 3-Phase, 50/60 Hz (If Electric)
- Compressed Air: N/A
- Rack Height: 36"-44"

DIMENSIONS

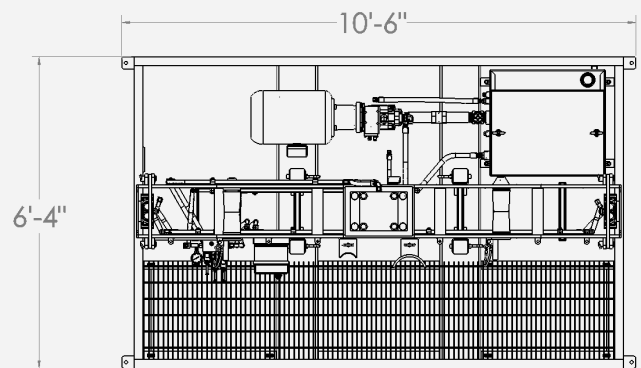
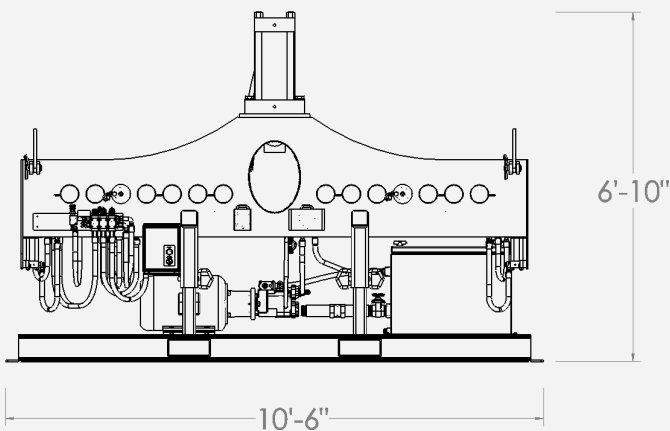

Hub City Iron Works

Phone: 1.337.334.6969

Email: sales@hubcityironworks.com

Website: www.hubcityironworks.com

