

HUB CITY
IRON WORKS

Thread Protector Cleaner

(Standard Capacity)

Operation and Maintenance Manual

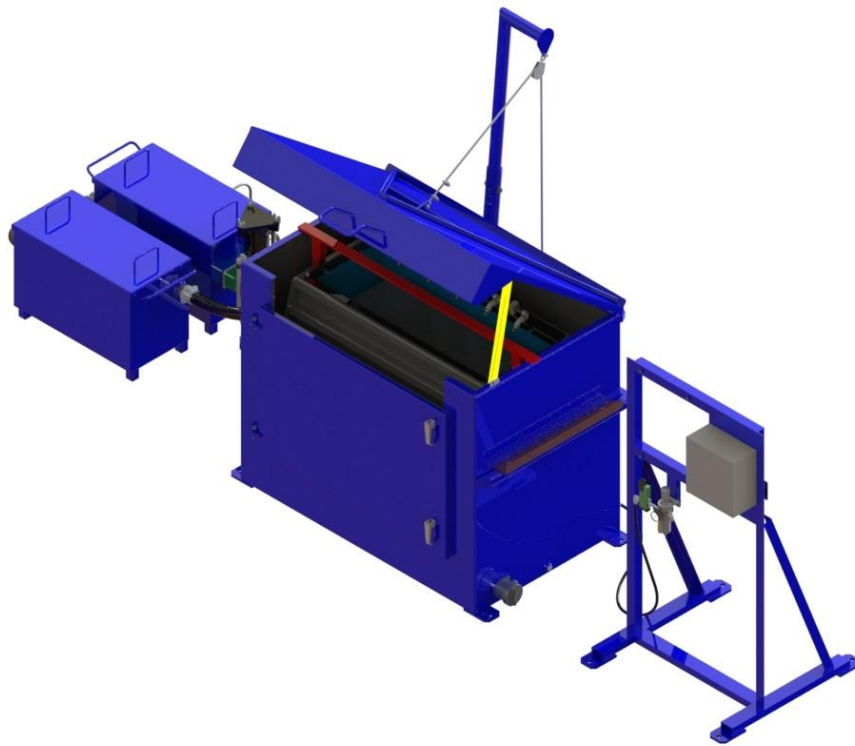

Hub City Iron Works
700 E Texas Ave.
Rayne, LA 70578
Phone: (337) 334-6969
Fax: (337) 365-6565
www.hubcityironworks.com

Customer: _____
Location: _____
Job #: _____
Local Rep: _____
Rep Phone # _____
Document # _____

Table of Contents

| | |
|---------------------------------------|----|
| Introduction | 3 |
| Safety | 3 |
| Machine Specifications | 4 |
| Standard Features | 4 |
| Specifications | 4 |
| Plant Requirements | 4 |
| Machine Setup | 5 |
| Controls | 6 |
| Process | 7 |
| Troubleshooting | 7 |
| Preventative Maintenance | 8 |
| Daily Preventative Maintenance | 8 |
| Weekly Preventative Maintenance | 9 |
| Yearly Preventative Maintenance | 10 |
| Parts List | 11 |
| Filter/Reservoir Tanks | 11 |
| MOTOR/SPRING ASSEMBLY | 12 |
| Tank | 13 |
| Recommended Spare Parts | 14 |
| Electrical Schematic | 15 |
| Hose Schematic..... | 16 |
| Pneumatic Schematic | 17 |

Service

Call: 337.334.6969

Email: servicerequest@hubcityironworks.com

Spare Parts

Call: 337.334.6969

Visit: www.hubcityironworks.com

Sales

Call: 337.334.6969

Email: sales@hubcityironworks.com

Introduction

Thread Protector Cleaner, Standard Capacity

Hub City Iron Works' Thread Protector Cleaning Machine uses a petroleum base solvent with a ceramic media to rub against the ID and OD surface of thread protectors – plastic or metal – providing an unbeatable cleaning solution. The process, which takes approximately 30 minutes, uses an industrial strength vibratory motor to remove debris and built-up thread compound from thread protectors. This unit, in addition to being quick and effective, eliminates the human element from the cleaning process, increasing the safety factor.

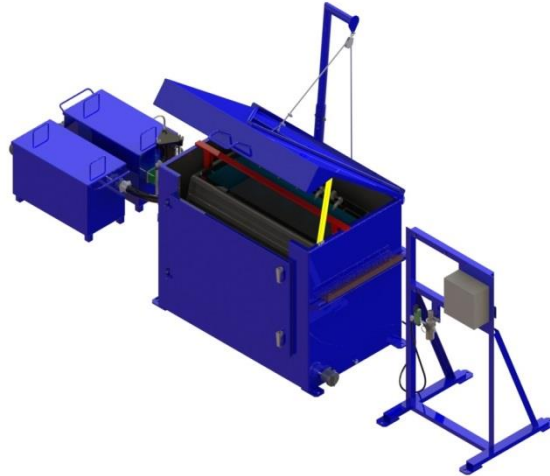

Safety

Hub City has provided operating procedures and safety information to ensure the wellbeing of both the operator and the equipment.

This operating manual contains important safety information - please read it thoroughly.

Safety Features Include:

- Mechanically active components are painted a high visibility yellow.
- Equipment safety labels.
- Safety bar for securely raising the lid for access

Machine Specifications

Standard Features

- Vibratory motor
- Ceramic media
- Diaphragm air operated cleaning solution recirculation pump
- Particulate settling and filtering tanks
- Pump filtration system
- Run timer

Specifications

| Thread Protector Size | Approximately Capacity |
|-----------------------|------------------------|
| 2-3/8" | 200 |
| 2-7/8" | 175 |
| 3-1/2" | 150 |
| 4" | 125 |
| 4-1/2" | 100 |
| 5" | 75 |
| 5-1/2" | 50 |
| 6-5/8" | 25 |

Plant Requirements

- Electrical 480V, 3 Phase, 60 Hz, 30ams (Others by request)
- Footprint 16' x 6' x 8'
- Pneumatic 100psi @ 30CFM

Machine Setup

For proper operation, the machine must be installed as per the instructions below.

1. Orient unit according to layout below.

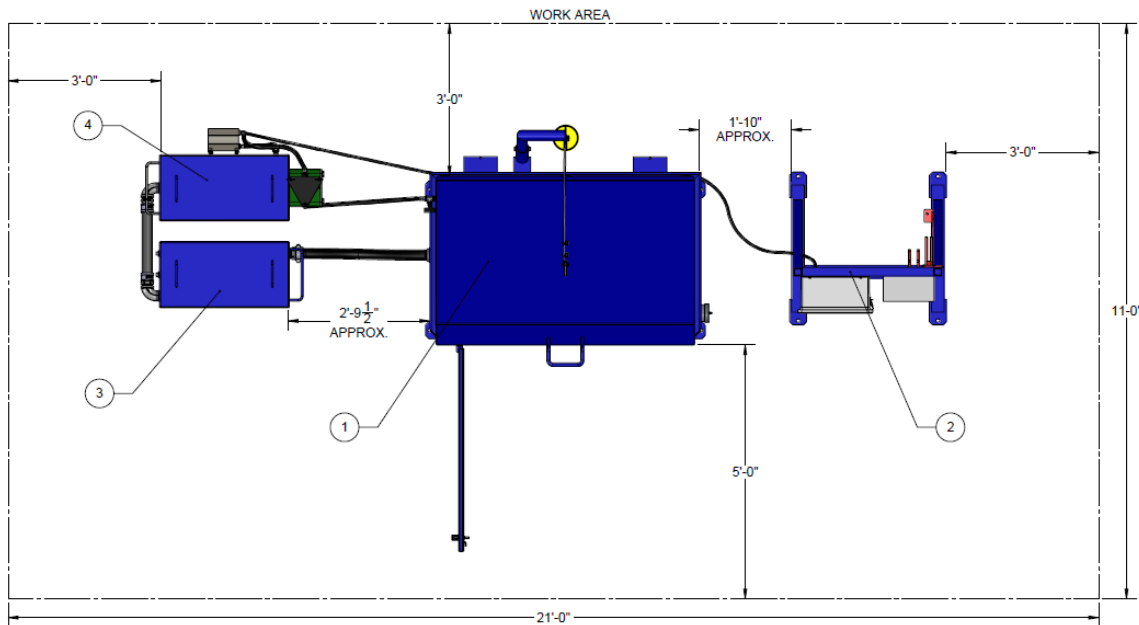

2. Connect hoses as indicated on page 16 & 17
3. Hook up electrical system as indicated on page 15
4. Remove front and rear shipping brackets, painted red, and as shown below in red, store brackets behind control panel.

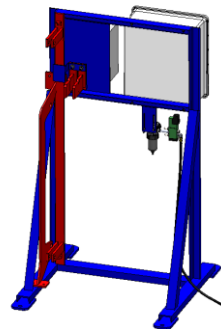
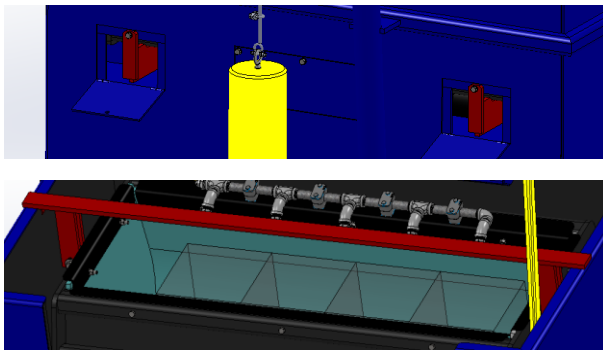

5. Fill unit with 25 gallons of “Crystal Clean Premium 142 Mineral Spirits” or equivalent
6. Add ceramic media (400 pounds)
7. Run Machine for 8 hours.
 - a. Check line current to make sure that it does not exceed nameplate
 - b. Check vibratory motor mounting bolt torque, 430 ft-lbs (dry)

Controls

Standard Thread Protector Cleaner Controls

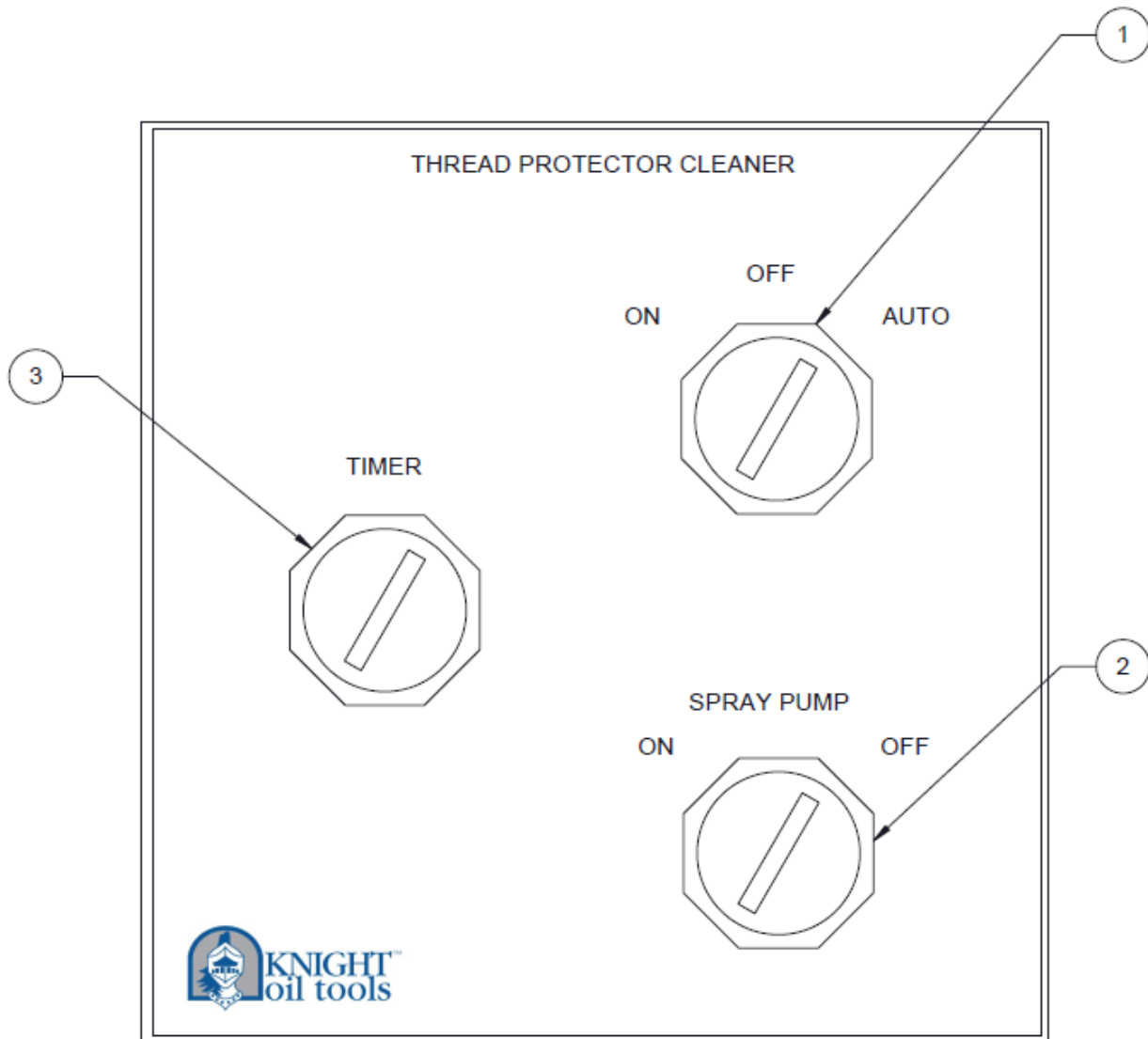

| | <u>Function</u> | <u>Description / Comments</u> |
|---|------------------------|--|
| 1 | Power Switch | Turns vibratory motor on and off. On: Turns motor on indefinitely Auto: Turns motor on for duration of timer |
| 2 | Spray Pump Switch | Turns spray system on and off |
| 3 | Timer | Turns off machine when set to "Auto" |

Process

Startup/Operation

1. Ensure that it is safe to operate machinery and all personnel are clear.
2. Verify that daily preventative maintenance has been performed.
3. Turn the Power switch (**Control #1**) to “on” or “auto”. If “auto” is selected, set time desired (**Control #3**) and ensure ceramic media is circulating properly.
 - a. Power Switch Functions
 - i. On – unit will run indefinitely
 - ii. Off – Power to vibratory motor is off
 - iii. Auto – Unit will run according to the timer (**Control #3**)
4. Turn spray pump on (**Control #2**)
5. Add thread protectors up to the maximum number.
 - a. See table under specifications for capacity limits.

Troubleshooting

| Problem | Cause | Corrective Action |
|---|--|---|
| Unit does not spray | <ul style="list-style-type: none"> • Filters are clogged • Low air pressure • Spray nozzles are clogged | <ul style="list-style-type: none"> • Clear filters of debris • Check that air is turned on and pressure regulator is set to 60 PSI • Clear obstructions from spray nozzles |
| Unit not cleaning properly | <ul style="list-style-type: none"> • Filtration tanks are full • Cleaning solution is dirty • Ceramic media is worn | <ul style="list-style-type: none"> • Empty filtration tanks • Replace cleaning solution • Replace ceramic media |
| Media or thread protectors do not circulate | <ul style="list-style-type: none"> • Inadequate amount of ceramic media • Springs are not aligned | <ul style="list-style-type: none"> • Add ceramic media • Align springs |

Preventative Maintenance

Daily Preventative Maintenance

| | |
|---|--|
|  | <h1 style="margin: 0;">TPC Daily Preventative Maintenance</h1> |
|---|--|

Company: _____
 Location: _____
 Machine No.: _____
 Week of: _____



Instructions:
 Inspect each item at the start of each shift - initial next to block after task is complete
 For more detailed information consult operators manual.

| Day | Filtration Tanks (1) Check for excess buildup, clean as needed (2) Inspect pump filter for blockage (3) Inspect hoses for wear/leaks | Inspect control console (1) Loose wires and proper function (2) switches and joysticks for loose and/or broken wires | Spray Nozzles (1) Inspect for blockage. Clean as needed | Hoses (Inspect all hoses for wear/leaks) | | | | | | | | |
|-----|--|---|---|--|--|--|--|--|--|--|--|--|
| 1 | | | | | | | | | | | | |
| 2 | | | | | | | | | | | | |
| 3 | | | | | | | | | | | | |
| 4 | | | | | | | | | | | | |
| 5 | | | | | | | | | | | | |
| 6 | | | | | | | | | | | | |
| 7 | | | | | | | | | | | | |

Comments:

Weekly Preventative Maintenance



TPC Weekly Preventative Maintenance

Company: _____
 Location: _____
 Machine No.: _____
 Week of: _____

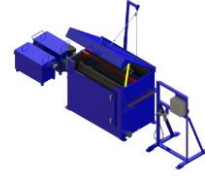

Instructions:
 Inspect each item once per week - initial next to block after task is complete
 For more detailed information consult operators manual.

| Week | Filtration Tanks (1) Check cleaning solution. Change if needed (4) Clean filtration tanks | Tub (1) Check ceramic media for wear. Replace if needed (2) Check tub springs for proper alignment (3) Check tub lining for damage | Lid System (1) Inspect cable and clamps for wear. Replace if needed (2) Ensure lid latch functions properly | | | | | | | | |
|------|--|--|--|--|--|--|--|--|--|--|--|
| | | | | | | | | | | | |
| | | | | | | | | | | | |
| | | | | | | | | | | | |
| | | | | | | | | | | | |
| | | | | | | | | | | | |
| | | | | | | | | | | | |
| | | | | | | | | | | | |
| | | | | | | | | | | | |

Comments:

Yearly Preventative Maintenance



TPC Yearly Preventative Maintenance

Company: _____
 Location: _____
 Machine No.: _____
 Week of: _____



Instructions:
 Inspect each item once every **2,000 hours** - initial next to block after task is complete
 For more detailed information consult operators manual.

| Year | Vibratory Motor (1)Retorque vibratory motor mounting bolts (430 ft-lbs (Dry) (2)Grease w/ "Kluber ISOFLUX TOPAS NB) | | | | | | | | | | | | |
|------|---|--|--|--|--|--|--|--|--|--|--|--|--|
| | | | | | | | | | | | | | |
| | | | | | | | | | | | | | |
| | | | | | | | | | | | | | |
| | | | | | | | | | | | | | |
| | | | | | | | | | | | | | |
| | | | | | | | | | | | | | |
| | | | | | | | | | | | | | |
| | | | | | | | | | | | | | |

Comments:

Parts List

Filter/Reservoir Tanks

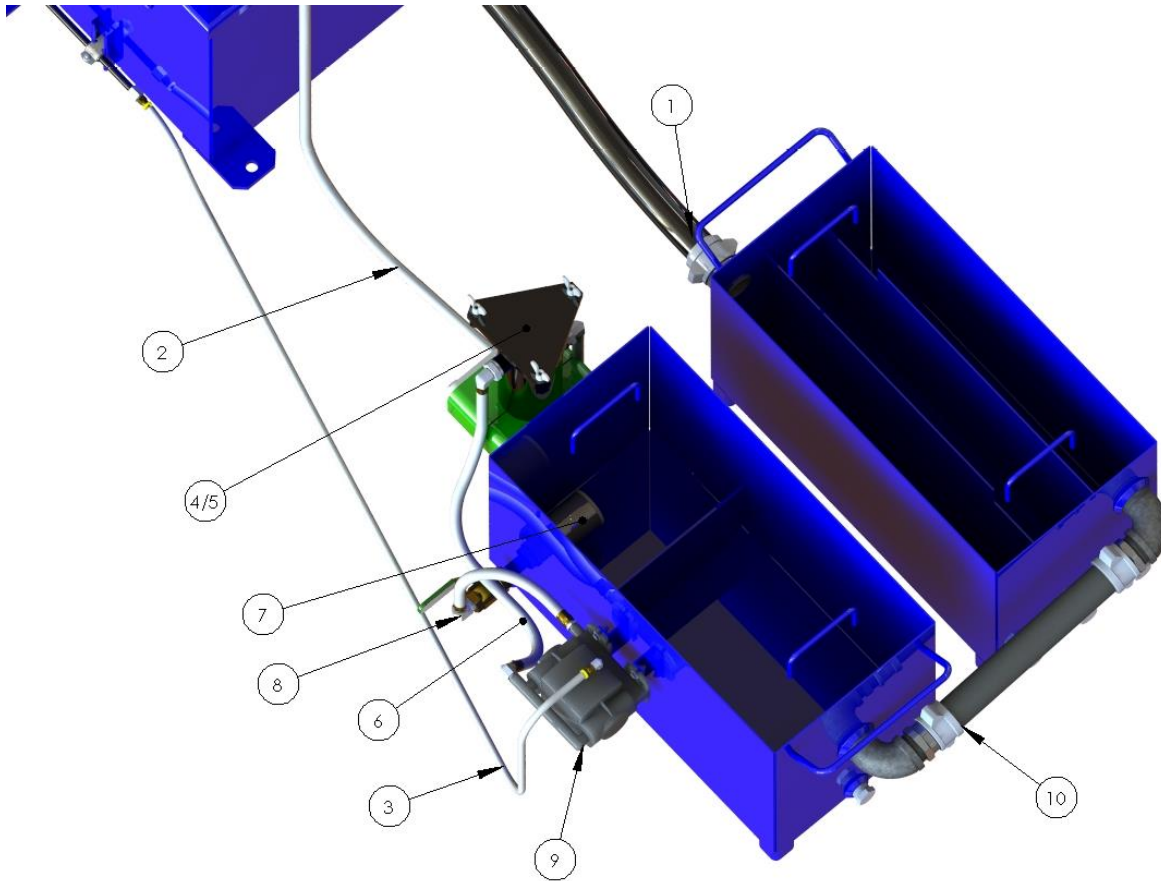

| Item # | Part | Description | Quantity |
|--------|----------------|---|----------|
| 1 | 22023 | CLEANING FLUID RETURN HOSE | 1 |
| 2 | 002-610-002-00 | CLEANING FLUID SUPPLY HOSE | 1 |
| 3 | 002-610-005-00 | AIR SUPPLY HOSE | 1 |
| 4 | 15315 | FILTER HOUSING | 1 |
| 5 | 15342 | FILTER SOCK | 1 |
| 6 | 002-610-004-00 | PUMP-FILTER HOSE | 1 |
| 7 | 21628 | SUCTION STRAINER | 1 |
| 8 | 002-610-003-00 | PUMP SUCTION HOSE | 1 |
| 9 | 44424 | AIR DIAPHRAGM PUMP | 1 |
| | 44572 | PUMP RETROFIT KIT (FOR MACHINES MANUFACTURED BEFORE 2014) | 1 |
| 10 | 22024 | CLEANING FLUID TANK TRANSFER HOSE | 1 |

MOTOR/SPRING ASSEMBLY

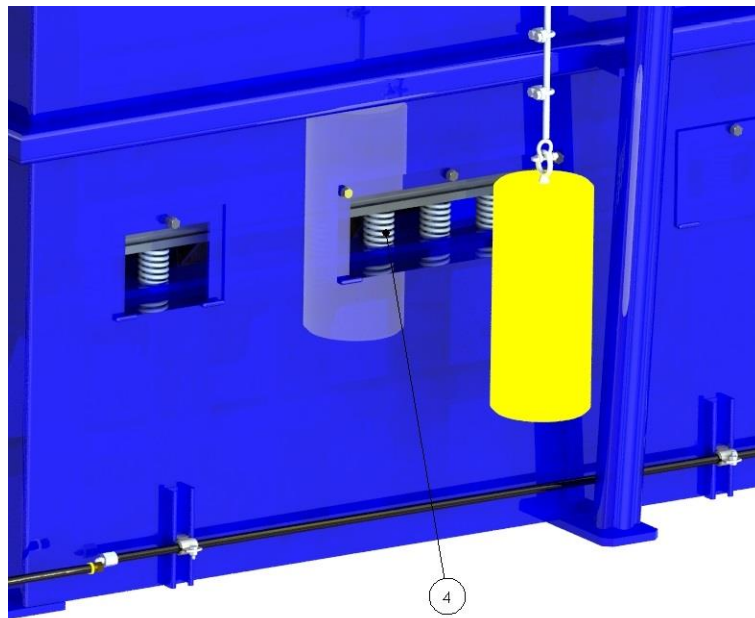
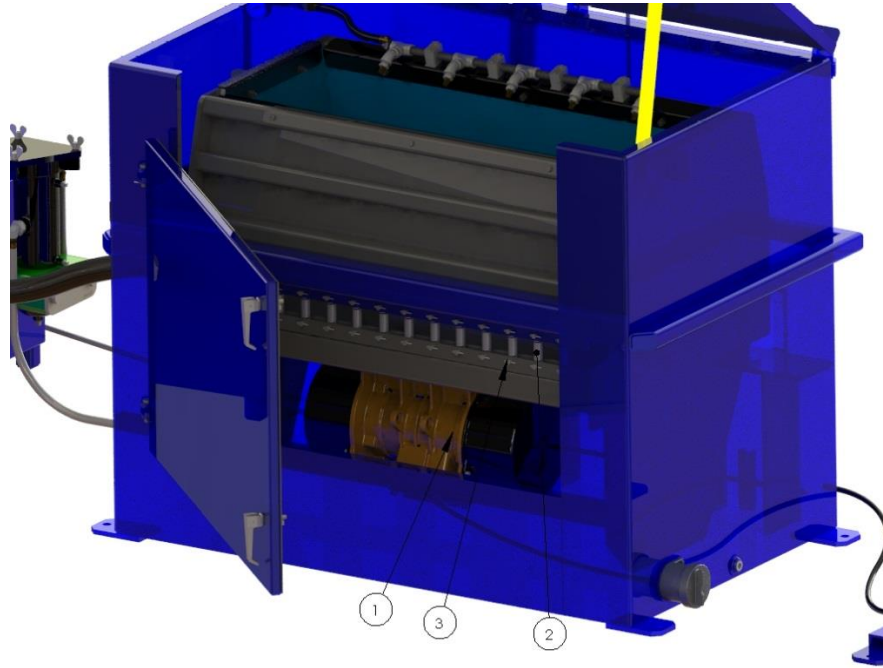

| Item # | Part # | Description | Quantity |
|--------|--------|-------------------------|----------|
| 1 | 16447 | VIBRATORY MOTOR | 1 |
| 2 | 13966 | FRONT EXTENSION SPRINGS | 13 |
| 3 | 14824 | SPRING PIN | 13 |
| 4 | 13967 | REAR COMPRESSION SPRING | 8 |

Tank

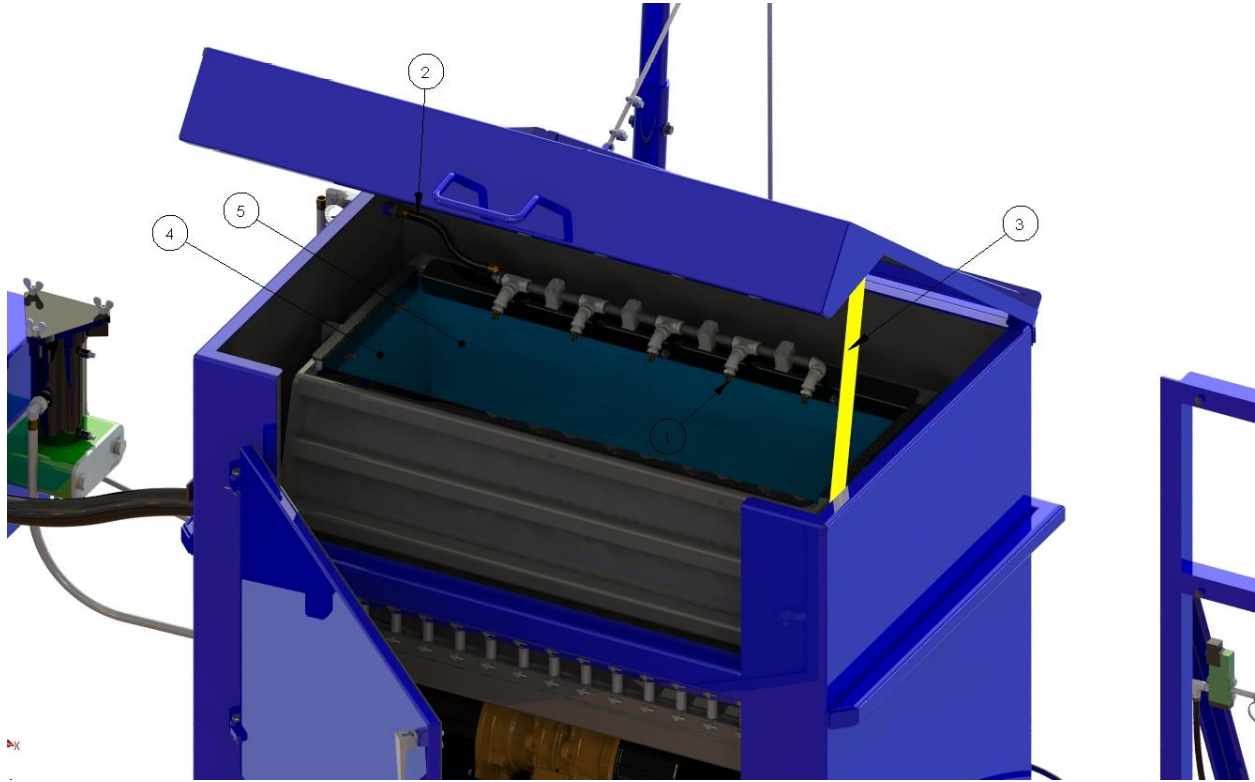

| Item # | Part | Description | Quantity |
|--------|-----------------|---------------------|----------|
| 1 | 14008 | SPRAY NOZZLE | 5 |
| 2 | 002-610-001-00 | SRAY HOSE | 1 |
| 3 | 002-100-071-018 | SAFETY BAR | 1 |
| 4 | 002-200-016-XXX | SIDE WEAR COATING | 2 |
| 5 | 002-200-014-XXX | CENTER WEAR COATING | 1 |

Recommended Spare Parts

| Level A Items (Stocked on site) | | |
|---|-----|-------|
| Description | Qty | SAP# |
| FILTER SOCK (25 Micron) | 10 | 15342 |
| FILTER SOCK (5 Micron) | 10 | 15343 |
| Spray Nozzle | 5 | 14008 |
| Ceramic Media (50lb) | 2 | 13370 |
| Timer | 1 | 14056 |
| Fuse, 8A | 3 | 23182 |
| Level B Items (1-3 Day Delivery) | | |
| Diaphragm Pump (<i>Pre 2014</i>) | 1 | 16940 |
| Diaphragm Pump (<i>Post 2014</i>) | 1 | 44424 |
| Suction Strainer | 1 | 21628 |
| EXTENSION SPRINGS | 10 | 13966 |
| SPRING PIN | 10 | 14824 |
| COMPRESSION SPRING | 10 | 13967 |
| Air Valve | 1 | 17558 |
| Air Regulator | 1 | 16022 |
| Contactora | 1 | 14976 |
| Motor Overload | 1 | 17023 |
| Selector Switch, 2 position | 1 | 13989 |
| Selector Switch, 3 position | 1 | 17404 |
| Level C Items (0-120 Day Delivery) | | |
| Vibratory Motor, Single | 1 | 16447 |
| Vibratory Motor, Double Assembly | 1 | 26739 |
| Transformer | 1 | 17521 |

Electrical Schematic

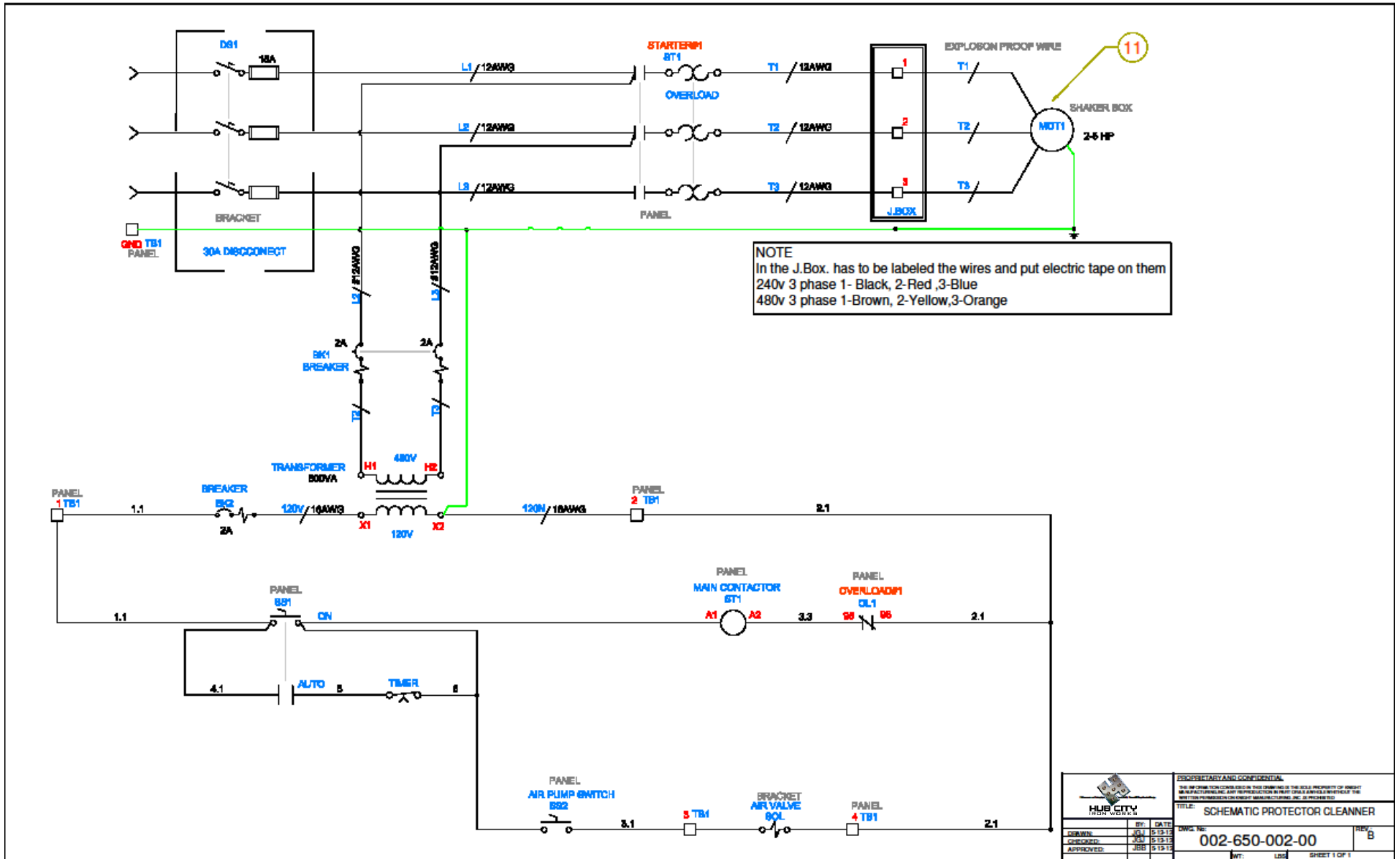

Hose Schematic

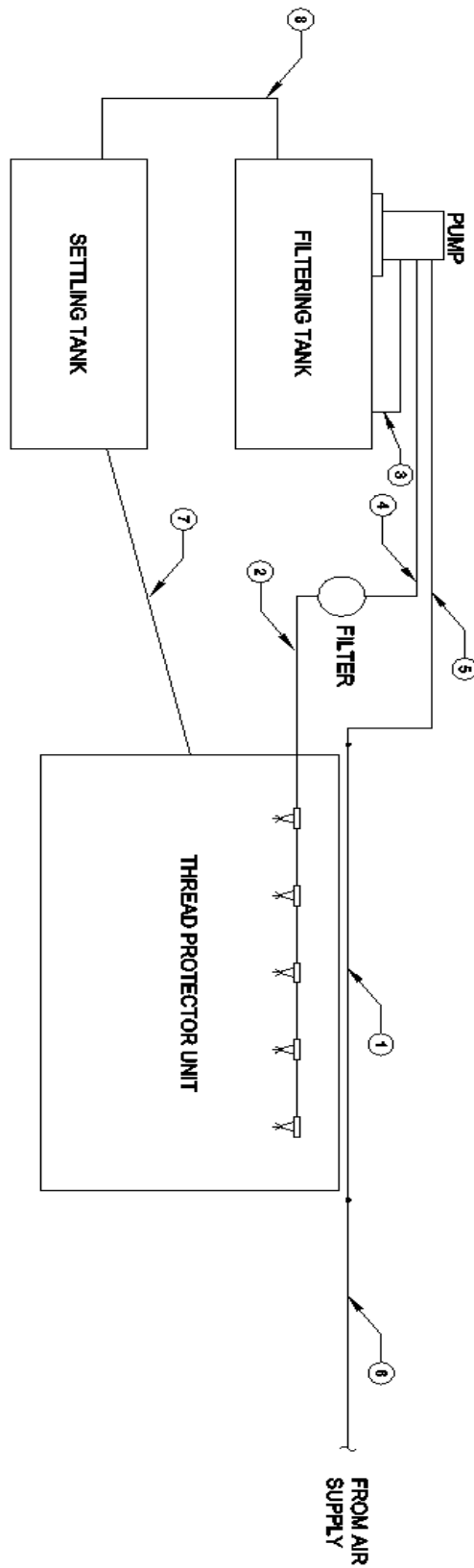

| ITEM | QTY. | DESCRIPTION | PART NO. |
|------|------|------------------------------|-----------------|
| 1 | 1 | AIR PIPE ASSEMBLY | 002-599-002-000 |
| 2 | 1 | HOSE ASSEMBLY | 002-610-002-00 |
| 3 | 1 | HOSE ASSEMBLY | 002-610-003-00 |
| 4 | 1 | HOSE ASSEMBLY | 002-610-004-00 |
| 5 | 1 | AIR HOSE ASSEMBLY | 002-610-005-00 |
| 6 | 1 | AIR HOSE ASSEMBLY | 002-610-006-00 |
| 7 | 1 | WATER SUCTION HOSE 2" X33" | 22023 |
| 8 | 1 | WATER SUCTION HOSE 2" X18.5" | 22024 |

Pneumatic Schematic

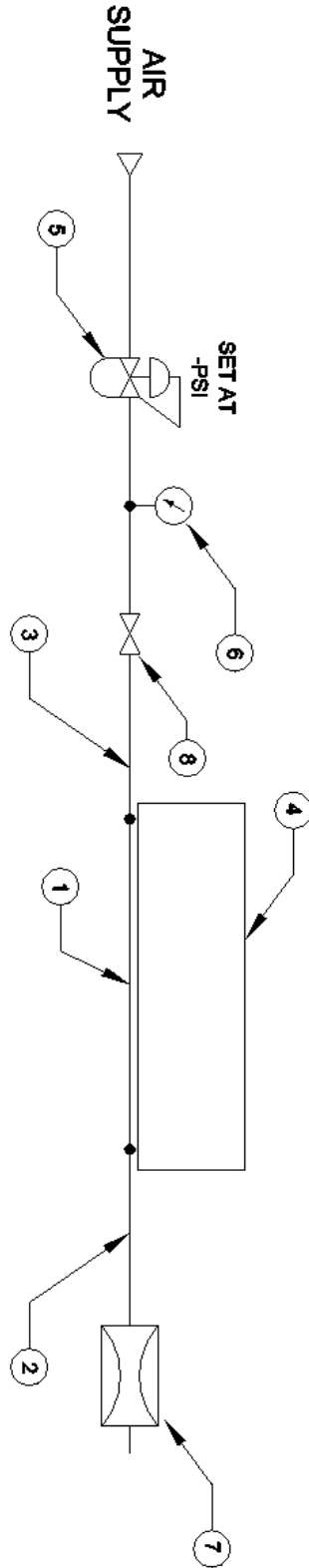

| ITEM | QTY. | DESCRIPTION | PART NO. |
|------|------|-----------------------|-----------------|
| 1 | 1 | AIR PIPE ASSEMBLY | 002-599-002-000 |
| 2 | 1 | AIR HOSE ASSEMBLY | 002-610-005-00 |
| 3 | 1 | AIR HOSE ASSEMBLY | 002-610-006-00 |
| 4 | 1 | THREAD PROTECTOR UNIT | 002-701-103-00 |
| 5 | 1 | FILTER REGULATOR | 16022 |
| 6 | 1 | PRESSURE GAUGE | 16060 |
| 7 | 1 | DIAPHRAM PUMP | 16940 |
| 8 | 1 | AIR VALVE | 17558 |