

HUB CITY
IRON WORKS

Thread Protector Cleaner

(Standard Capacity)

Operation and Maintenance Manual

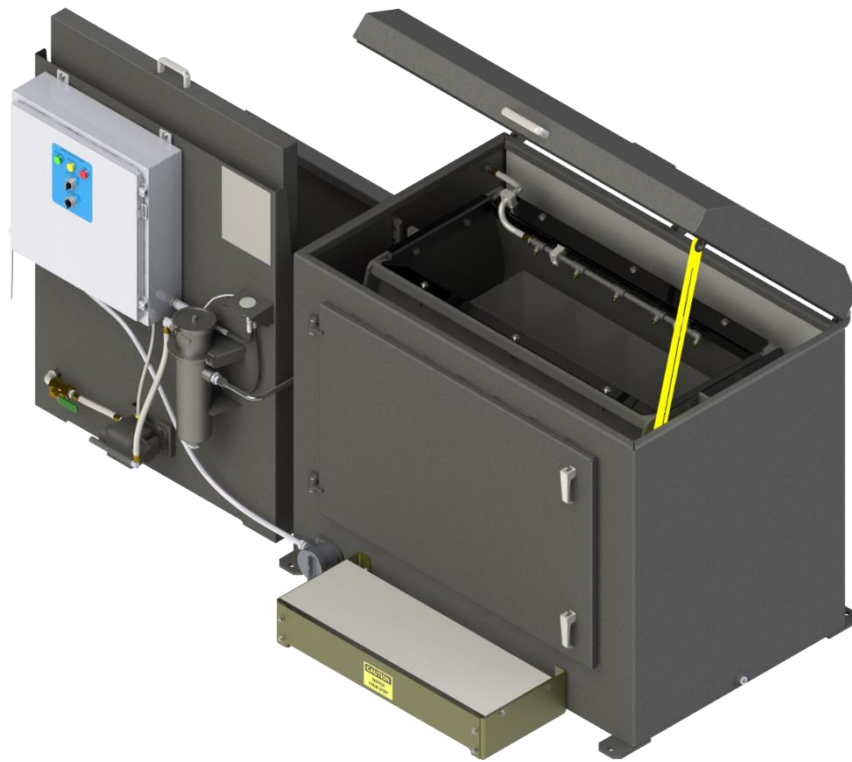

Hub City Iron Works
700 E Texas Ave.
Rayne, LA 70578
Phone: (337) 334-6969
Fax: (337) 365-6565
www.hubcityironworks.com

Customer: _____
Location: _____
Job #: _____
Local Rep: _____
Rep Phone # _____
Document # _____

Table of Contents

Introduction	3
Safety	3
Machine Specifications	4
Standard Features	4
Specifications	4
Plant Requirements	4
Machine Setup	5
Controls	6
Process	7
Troubleshooting	7
Preventative Maintenance	8
Daily Preventative Maintenance	8
Weekly Preventative Maintenance	9
Yearly Preventative Maintenance	10
Parts List	11
Control Panel / Settling Tank	11
Motor/Spring Assembly	12
Tank	13
Recommended Spare Parts	14
Electrical Schematics	15
Power Schematic	15
Control Schematic	16
Plumbing Schematic	17

Service

Call: 337.334.6969

Email: servicerequest@hubcityironworks.com

Spare Parts

Call: 337.334.6969

Visit: www.hubcityironworks.com

Sales

Call: 337.334.6969

Email: sales@hubcityironworks.com

Introduction

Thread Protector Cleaner, Standard Capacity

Hub City Iron Works' Thread Protector Cleaning Machine uses non-flammable solvent with a ceramic media to rub against the ID and OD surface of thread protectors – plastic or metal – providing an unbeatable cleaning solution. The process, which takes approximately 30 minutes, uses an industrial strength vibratory motor to remove debris and built-up thread compound from thread protectors. This unit, in addition to being quick and effective, eliminates the human element from the cleaning process, thereby increasing the safety of nearby workers.

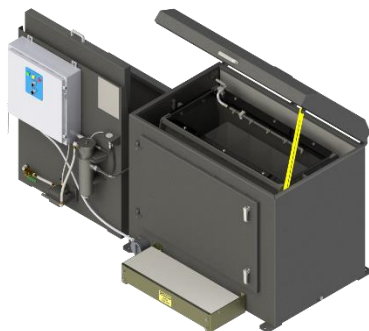

Safety

Hub City has provided operating procedures and safety information to ensure the wellbeing of both the operator and the equipment.

This operating manual contains important safety information - please read it thoroughly.

Safety Considerations:

- Always lockout/tagout machine before performing any maintenance.
- Always be mindful of pinch points when operating machine.
- Always wear hearing and eye protection when near machine.
- Never use flammable solvents.

Safety Features Include:

- Mechanically active components are painted a high visibility yellow.
- Equipment safety labels.
- Safety bar for securely raising the lid for access.

Machine Specifications

Standard Features

- Vibratory motor
- Ceramic media
- Diaphragm air operated cleaning solution recirculation pump
- Particulate settling and filtering tank
- Pump filtration system
- Filter differential pressure gauge
- Work platform
- Run timer

Specifications

- Machine Weight 2,750 lbs

Thread Protector Size	Approximately Capacity
2-3/8"	200
2-7/8"	175
3-1/2"	150
4"	125
4-1/2"	100
5"	75
5-1/2"	50
6-5/8"	25

Plant Requirements

- Electrical 480V, 3 Phase, 60 Hz, 30amps (Others by request)
- Foundation Concrete to be rated for 3,000 LBS
- Footprint 9'-0" wide x 4'-6" deep x 6'-6" high
- Pneumatic 30psi or greater @ 30CFM

Machine Setup

For proper operation, the machine must be installed as per the instructions below.

1. Orient unit according to layout below.

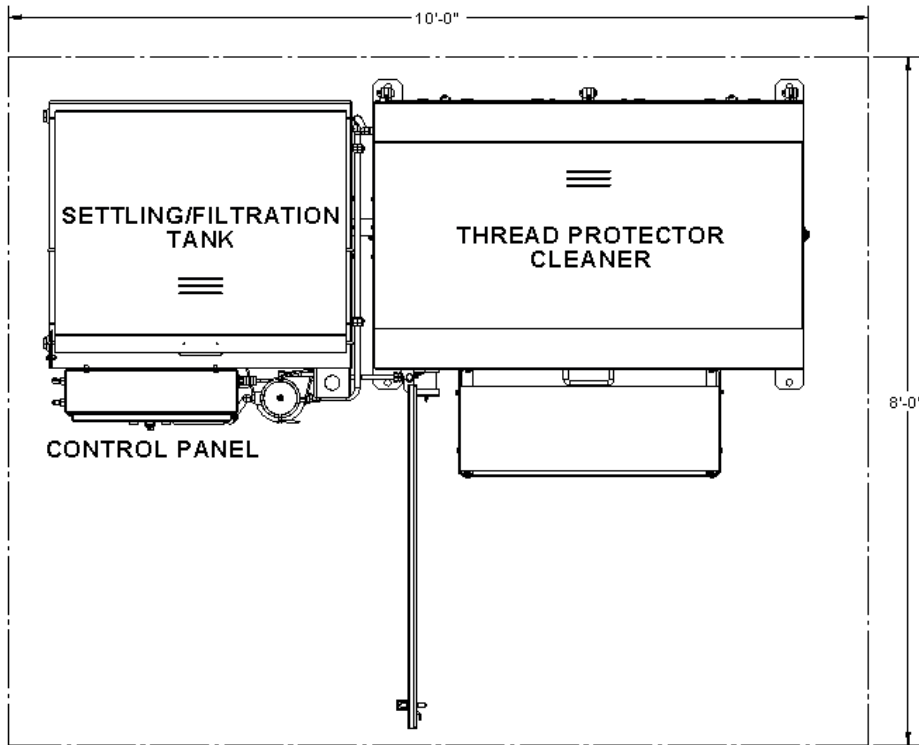

2. Connect pump jumper hose between Settling/Filtration Tank and Spay Bar.
3. Remove front and rear shipping brackets. (Shown below)
WARNING: FAILURE TO REMOVE SHIPPING BRACKETS BEFORE OPERATION CAN RESULT IN DAMAGE TO EQUIPMENT.

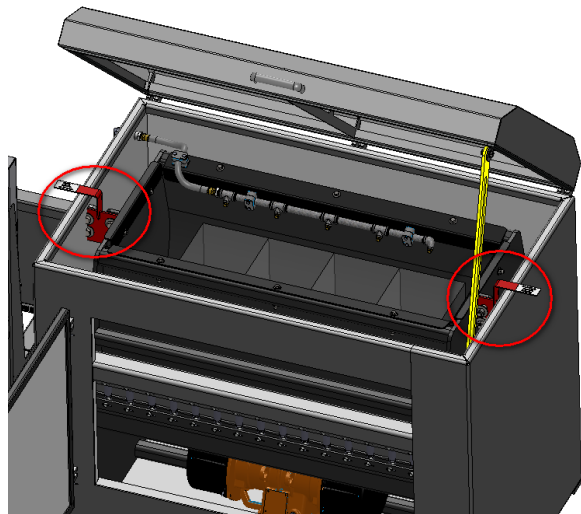

4. Connect electrical system as indicated on page 15
5. Fill unit with 55 gallons of *non-flammable* solvent.
6. Add ceramic media (400 pounds)
7. Run Machine for 8 hours.
 - a. Check line current to make sure that it does not exceed motor nameplate
 - b. Check vibratory motor mounting bolt torque, 430 ft-lbs (dry)

Controls

Standard Thread Protector Cleaner Controls

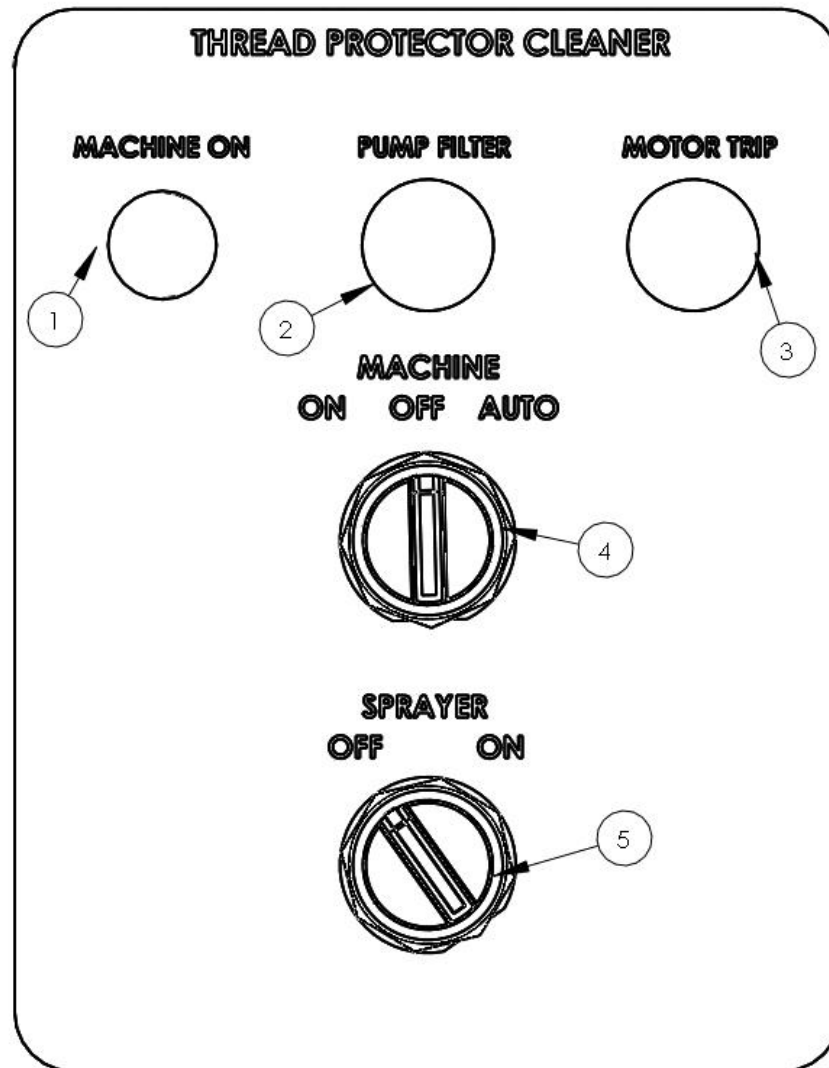

	<u>Function</u>	<u>Description / Comments</u>
1	“Machine On” Light	Light is on when machine is running
2	“Change Pump Filter” Light	Light turns on when it is time to change pump filter
3	“Motor Trip” Light	Light turns on when motor overload is tripped
4	Power Switch	Turns vibratory motor on and off. On: Turns motor on indefinitely Auto: Turns motor and sprayer on for duration of timer. Timer can be found inside panel.
5	Sprayer Switch	Toggles sprayer on and off when Power Switch is set to “ON” or “OFF”. When power switch is set to “AUTO”, the sprayer is automatically on for the duration of the cleaning cycle.

Process

Startup/Operation

1. Ensure that it is safe to operate machinery and all personnel are clear.
2. Verify that daily preventative maintenance has been performed.
3. Turn the Power Switch (**Control #4**) to “ON” or “AUTO”. If “AUTO” is selected, both the vibratory motor and the sprayer will operate for the duration of the timer. The timer can be found inside of the panel and can be set between 1 minute and 60 minutes. The most common cleaning cycle time is 30 minutes. If “ON” is selected, the vibratory motor will turn on indefinitely and the sprayer can be operated independently using (**Control #5**)
4. Turn spray pump on (If the “ON” setting is being used. (**Control #5**))
5. Add thread protectors up to the maximum number.
 - a. See table under specifications for capacity limits.

Troubleshooting

Problem	Cause	Corrective Action
Unit does not spray	<ul style="list-style-type: none"> • Filter is clogged • Low air pressure • Spray nozzles are clogged 	<ul style="list-style-type: none"> • Clear filters of debris • Check that air is turned on and pressure regulator is set to 30 PSI • Clear obstructions from spray nozzles
Unit not cleaning properly	<ul style="list-style-type: none"> • Filtration tanks are full • Cleaning solution is dirty • Ceramic media is worn 	<ul style="list-style-type: none"> • Empty filtration tanks • Replace cleaning solution • Replace ceramic media
Media or thread protectors do not circulate	<ul style="list-style-type: none"> • Inadequate amount of ceramic media • Springs are not aligned 	<ul style="list-style-type: none"> • Add ceramic media • Align springs
Machine is unusually loud and makes a “metal on metal banging sound”	<ul style="list-style-type: none"> • Check springs for wear or breakage 	<ul style="list-style-type: none"> • Replace any springs that are suspect of damage

Preventative Maintenance

Daily Preventative Maintenance



TPC Daily Preventative Maintenance

Company: _____
 Location: _____
 Machine No.: _____
 Week of: _____



Instructions:
 Inspect each item at the start of each shift - initial next to block after task is complete
 For more detailed information consult operators manual.

Day	Filtration Tanks (1) Check for excess buildup, clean as needed (2) Inspect pump filter for blockage	Inspect control console (1) Loose wires and proper function (2) switches and joysticks for loose and/or broken wires	Spray Nozzles (1) Inspect for blockage. Clean as needed										
1													
2													
3													
4													
5													
6													
7													

Comments:

Weekly Preventative Maintenance



TPC Weekly Preventative Maintenance

Company: _____
 Location: _____
 Machine No.: _____
 Week of: _____



Instructions:
 Inspect each item once per week - initial next to block after task is complete
 For more detailed information consult operators manual.

Week	Filtration/Settling Tank (1) Check cleaning solution. Change if needed (4) Clean filtration tanks (5) Replace filter if needed	Tub (1) Check ceramic media for wear. Replace if needed (2) Check tub springs for proper alignment (3) Check tub lining for damage	Lid System (2) Ensure lid latch functions properly							

Comments:

Yearly Preventative Maintenance



TPC Yearly Preventative Maintenance



Company: _____
 Location: _____
 Machine No.: _____
 Week of: _____

Instructions:
 Inspect each item once every **2,000 hours** - initial next to block after task is complete
 For more detailed information consult operators manual.

Year	Vibratory Motor (1) Retorque vibratory motor mounting bolts (430 ft-lbs (Dry)) (2) Grease w/ "Kluber ISO-FLEX TOPAS NB)											

Comments:

Parts List

Control Panel / Settling Tank

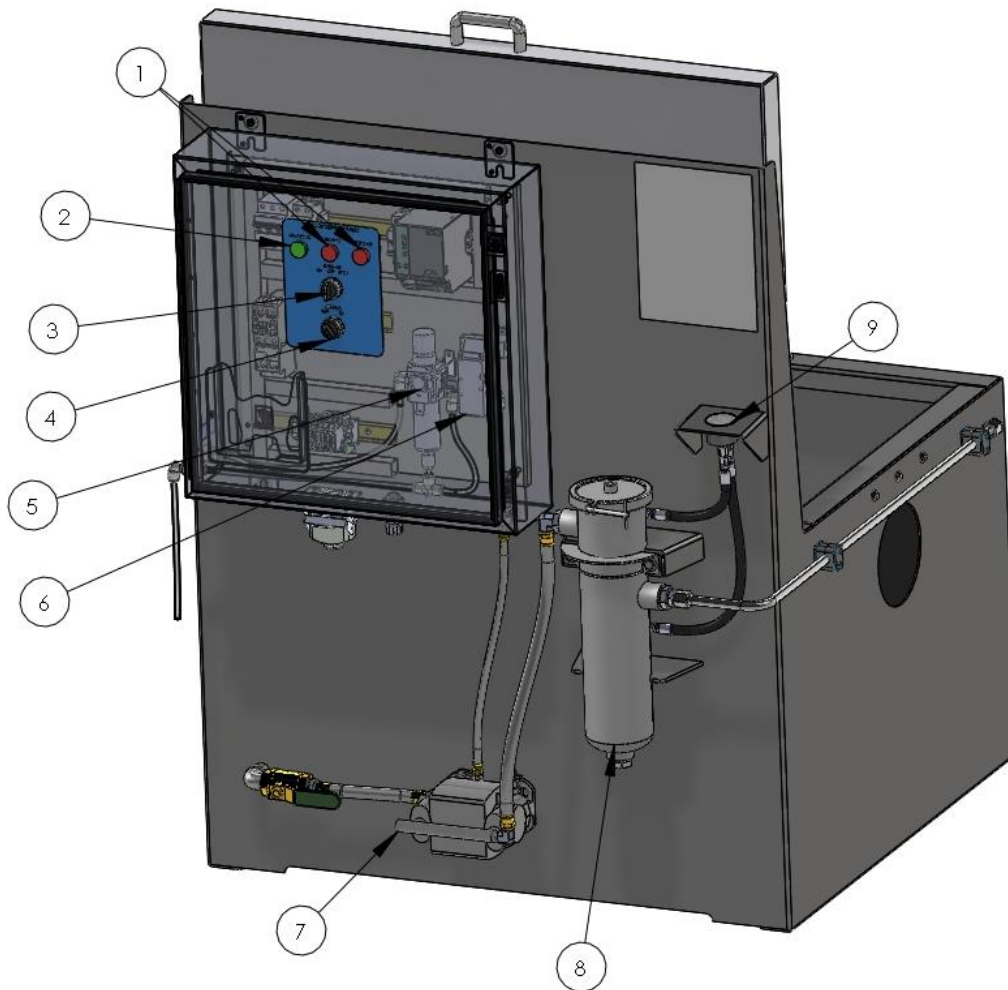

Item #	Part	Description	Quantity
1	16599	Light, Red	2
2	16598	Light, Green	1
3	17407	3-Position Switch	1
4	13989	2-Position Switch	1
5	48547	Air Regulator	1
6	48548	Air Valve	1
7	44424	Diaphragm Pump	1
8	48498	Filter Housing	1
9	48540	Differential Pressure Gauge	1
Not Shown	21628	Suction Strainer	1

Motor/Spring Assembly

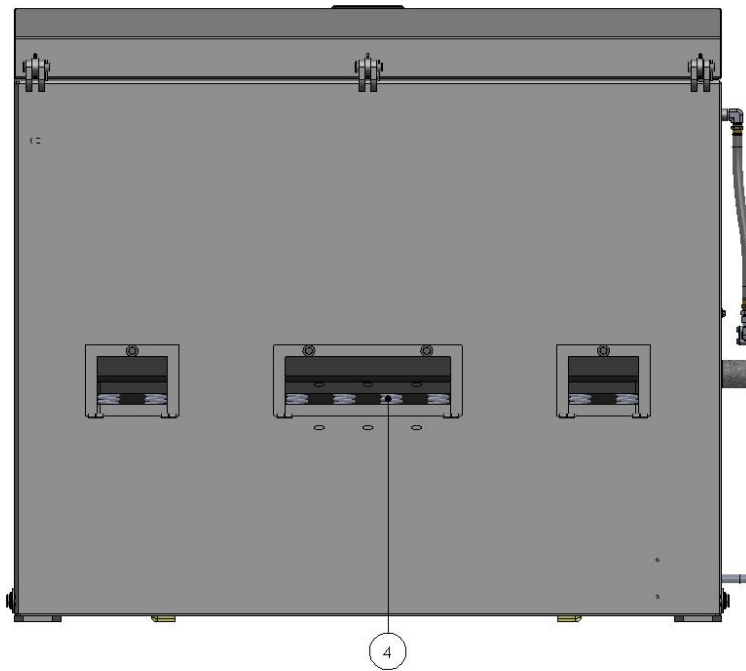
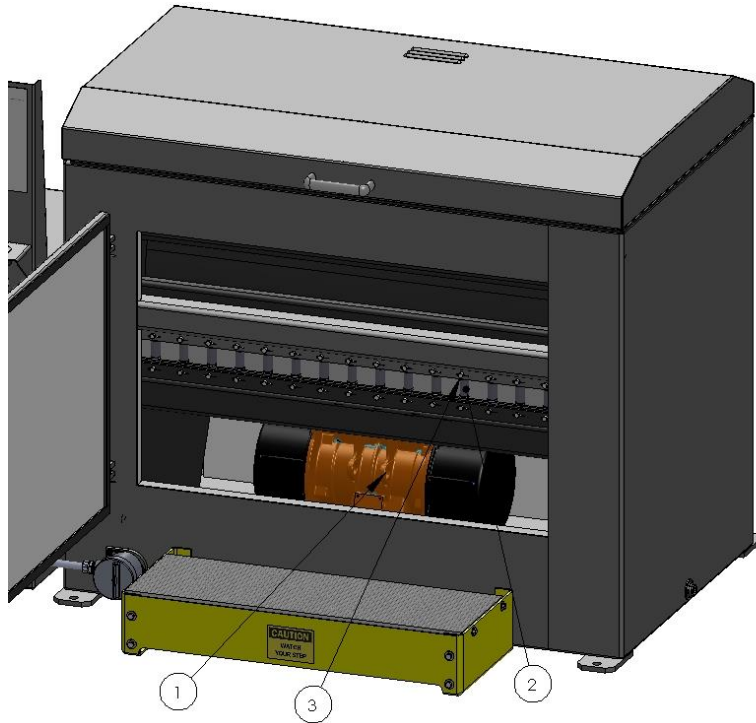

Item #	Part #	Description	Quantity
1	16447	VIBRATORY MOTOR	1
2	13966	FRONT EXTENSION SPRINGS	13
3	14824	SPRING PIN	13
4	13967	REAR COMPRESSION SPRING	8

Tank

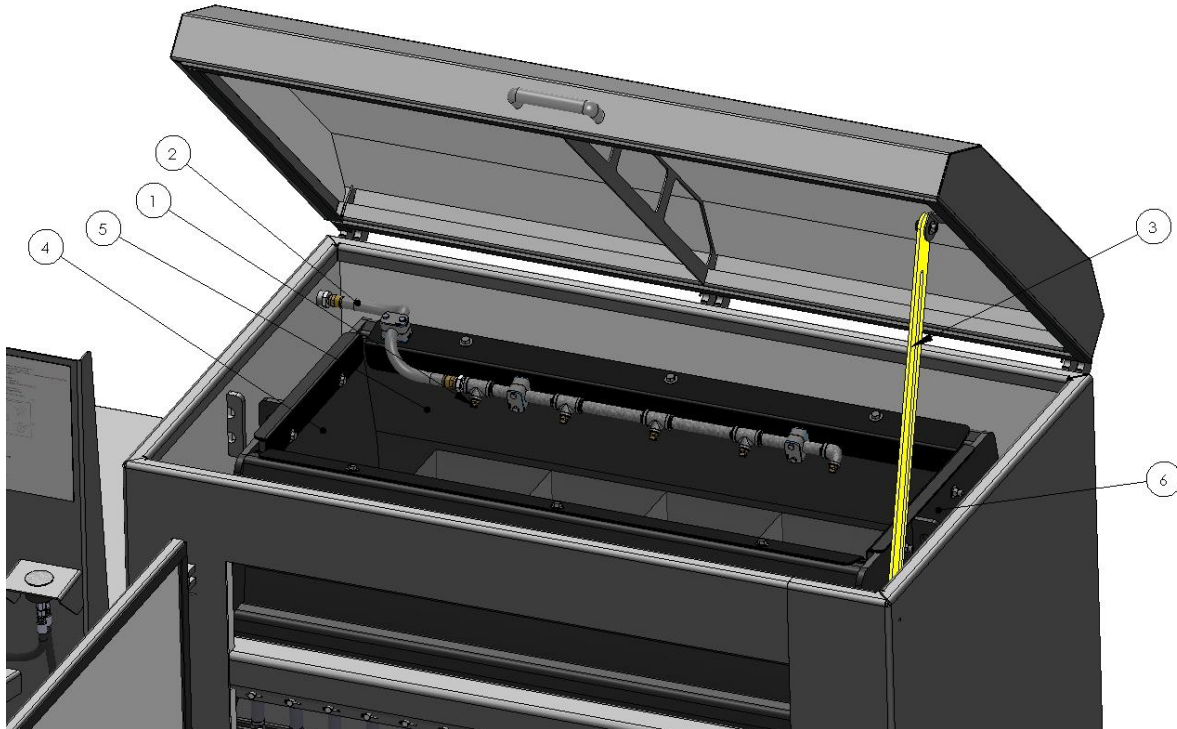

Item #	Part	Description	Quantity
1	14008	SPRAY NOZZLE	5
2	002-610-012-00	SRAY HOSE	1
3	002-150-044-018	SAFETY BAR	1
4	002-200-027-XXX	DRAIN SIDE WEAR LINER	1
5	002-200-028-XXX	CENTER WEAR LINER	1
6	002-200-015-XXX	SIDE WEAR LINER	1

Recommended Spare Parts

Level A Items (Stocked on site)		
Description	Qty	SAP#
Filter Sock (25 Micron)	10	15342
Filter Sock (5 Micron)	10	15343
Spray Nozzle	5	14008
Ceramic Media (50lb)	2	13370
Timer	1	38616
Level B Items (1-3 Day Delivery)		
Diaphragm Pump	1	44424
Suction Strainer	1	21628
Extension Springs	15	13966
Spring Pin	15	14824
Compression Spring	8	13967
Air Valve	1	VF51
Air Regulator	1	AW30
Contactator	1	14972
Motor Overload	1	47481
Selector Switch, 2 Position	1	13989
Selector Switch, 3 Position	1	17407
Level C Items (0-120 Day Delivery)		
Vibratory Motor, Single	1	16447

Electrical Schematics

Power Schematic

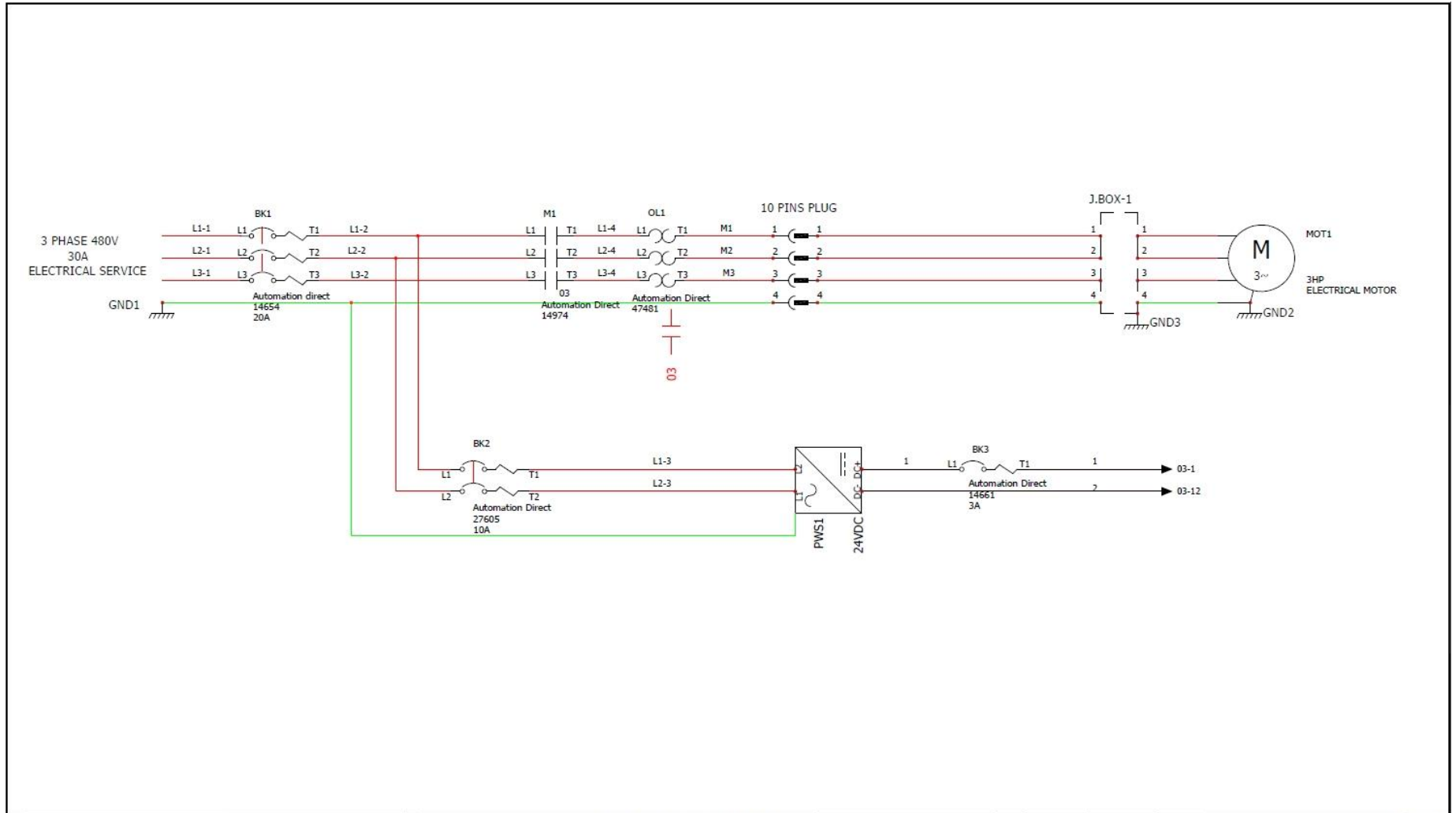

CONTRACT:		LOCATION: L1		ELECTRICAL PANEL		POWER SCHEMATIC		REVISION
						REV. 0	DATE 8/7/2015	NAME igonzalezjaitme
User data 2								SCHEME
								02

Control Schematic

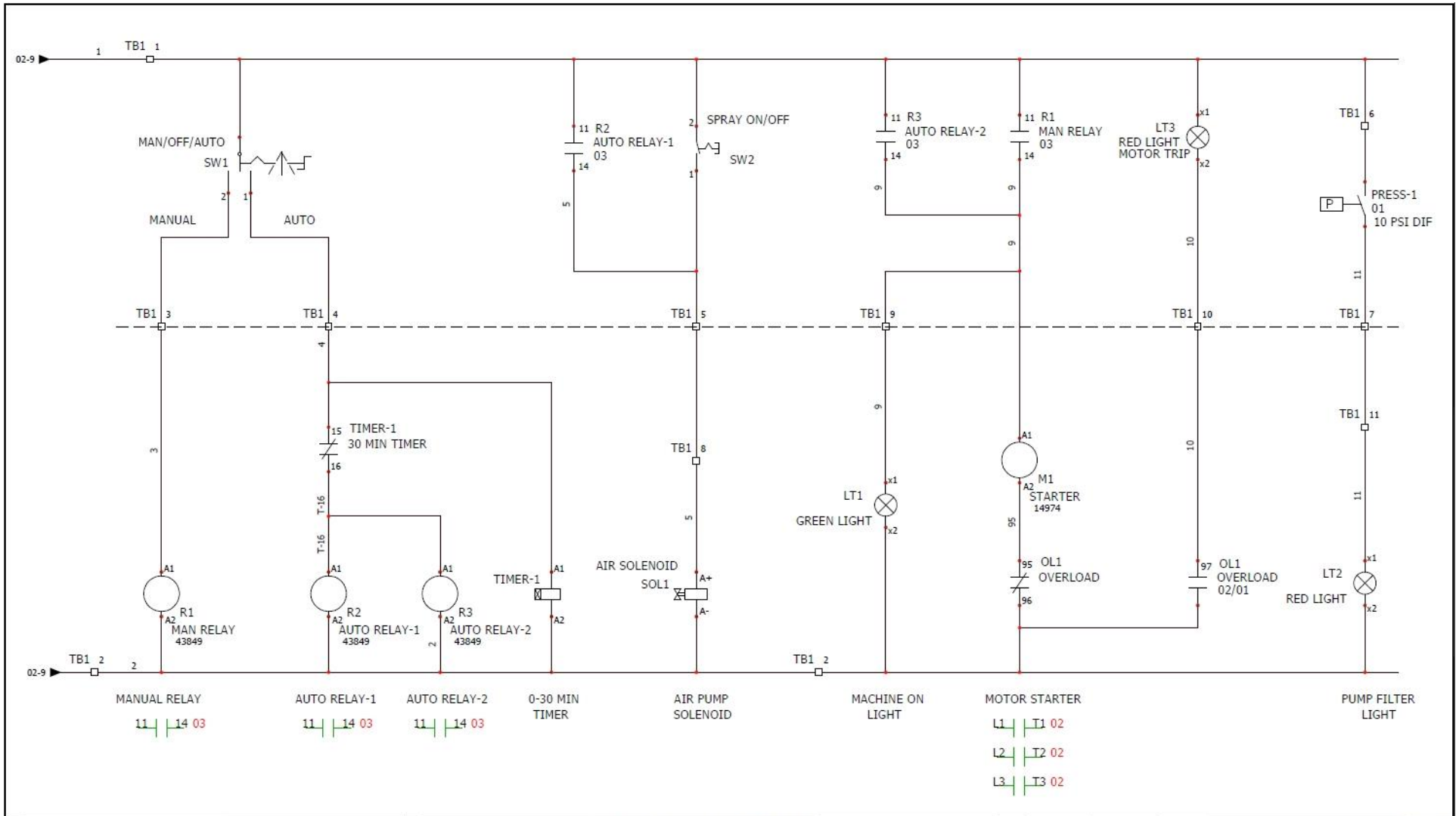

CONTROL SCHEMATIC

CONTRACT:	LOCATION: L1	ELECTRICAL PANEL	REVISION	0
			SCHEME	03
			REV.	0
			DATE	8/7/2015
			NAME	igonzalez@atme
			CHANGES	
User data 2				

Plumbing Schematic

ITEM	QTY.	DESCRIPTION	PART NO.
1	1	AIR REGULATOR	48547
2	1	AIR VALVE	48548
3	1	DIAPHRAGM PUMP	44424
4	1	FILTER HOUSING	48496
5	1	PRESSURE GAUGE	48540

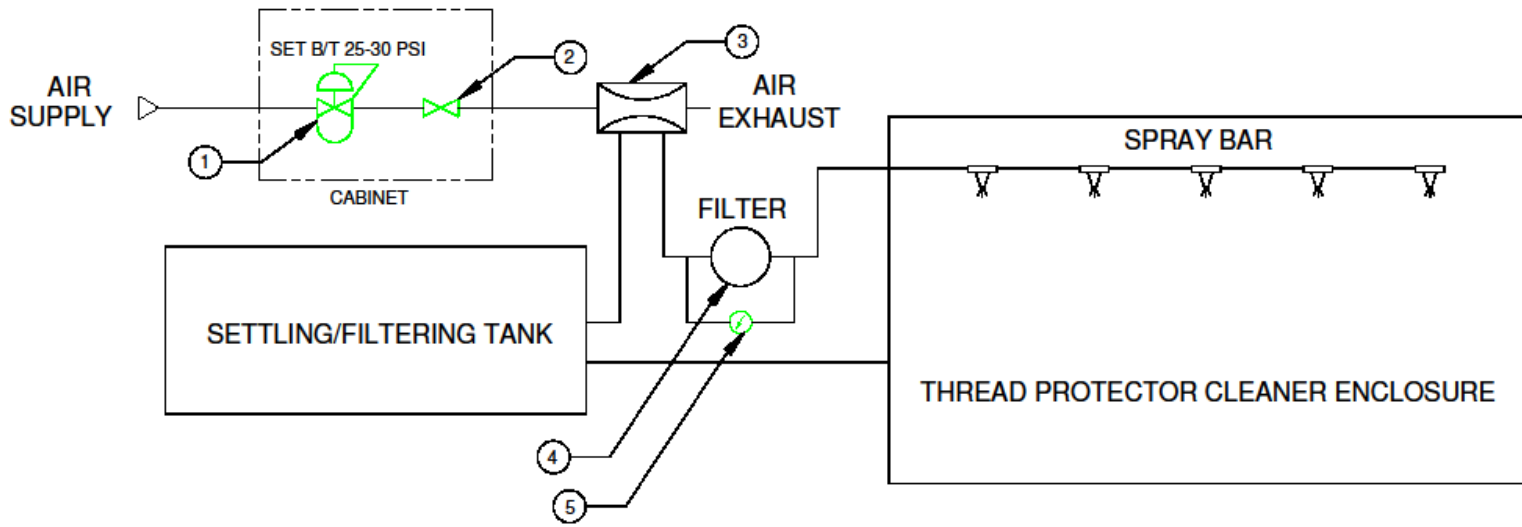

			PROPRIETARY AND CONFIDENTIAL THE INFORMATION CONTAINED IN THIS DRAWING IS THE SOLE PROPERTY OF KNIGHT MANUFACTURING, INC. ANY REPRODUCTION IN PART OR AS A WHOLE WITHOUT THE WRITTEN PERMISSION OF KNIGHT MANUFACTURING, INC. IS PROHIBITED.	
			TITLE: THREAD PROTECTOR HYDRAULIC SCHEMATIC	
DRAWN: JD CHECKED: JB APPROVED: JB	BY: JD DATE: 8/12/15	DWG. No: 002-800-001-00	REV: A	WT: LBS SHEET 1 OF 1